



Product Catalog

Tracer[®] SC System Controller For Tracer Building Automated Systems



May 2015

BAS-PRC031N-EN





Copyright

This document and the information in it are the property of Trane, and may not be used or reproduced in whole or in part without written permission. Trane reserves the right to revise this publication at any time, and to make changes to its content without obligation to notify any person of such revision or change.

Trademarks

All trademarks referenced in this document are the trademarks of their respective owners.



Table of Contents

Product Introduction	5
Tracer Building Automation System	6
Tracer SC System Architecture	7
BAS R'newal™ Program	8
Tracer® Communication Bridges	8
Tracer SC Facilities	9
User Interface	10
Alarms	10
Data Logs	11
Schedules	12
Overrides	13
Reports	14
Graphics and the Tracer Graphics Editor	15
Graphical and Bindable Widgets	17
Navigation Tree	18
User Security	18
System Control	19
Area Application	19
Variable Air Systems (VAS)	19
Chilled Plant Control (CPC)	19
Trane EarthWise™ Systems	20
Tracer Graphical Programming (TGP2)	20
Unit Control	22
BACnet (MS/TP) Unit Controllers Supported by Tracer SC	22
BACnet/IP Unit Controllers Supported by Tracer SC	22
Air-Fi Wireless Unit Controllers Supported by Tracer SC	22
LonTalk Unit Controllers Supported by Tracer SC	22
Trane Legacy Unit Controllers (Comm3/4) Supported by Tracer SC	23
Resources	24
Specifications	25
Hardware Components	28
Tracer SC System Controller	28
Dimensions	29
Trane PM014 Power Supply Module	29
Tracer® BACnet® Terminator	30

Medium Enclosure (optional)	30
Large Enclosure (optional)	32

Product Introduction









Tracer® SC allows you to streamline facility management without reinventing the entire system. Adding Tracer SC to your system provides a flexible, cost effective solution for building automation, and managing the facility climate that can extend to lighting and energy consumption. Accessible from most PCs, tablets and smart phones, Tracer SC eliminates the need for a dedicated computer and monitor so you can manage system performance whenever and wherever it is convenient. Tracer SC controller's simplified, Web-based management tool reduces scheduling, reporting and system application chores to simple "point and click" tasks. The intuitive online tools provide improved efficiencies, increased tenant comfort and reduced energy costs, which result in operational cost-savings and a better bottom line.

	<p>Occupant comfort and energy savings</p> <ul style="list-style-type: none"> Tracer SC includes several factory engineered HVAC applications that have been developed by HVAC system experts and tested on tens of thousands of facilities to ensure that your facility operates at its peak performance. These applications provide consistent comfort and improved indoor air quality, while reducing energy requirements. For any building owner concerned with energy, indoor air quality, and the environment, Trane EarthWise™ Systems represent a design philosophy whose time has come. EarthWise Systems provide documented sustainability of high efficiency and low emissions over the entire lifetime of the building. Tracer Graphical Programming (TGP2) is a powerful graphical program that can be used to customize factory applications or control non-HVAC equipment.
	<p>Access your facility from anywhere</p> <ul style="list-style-type: none"> Tracer SC is web-enabled and accessible from virtually any device with a web browser. All of the most popular device types, operating systems, and browsers are supported. The Tracer® BAS Operator Suite is a mobile app that allows you to monitor and manage buildings from virtually anywhere, giving you greater freedom and constant peace of mind.
	<p>Support for open, standard protocols</p> <ul style="list-style-type: none"> Open, standard protocols are the key to enabling communication among Trane and non-Trane HVAC equipment, as well as other complementary facility systems. These protocols enable communication across systems and vendors to ensure that your building operates at its best on day one and beyond. Tracer SC natively communicates to BACnet® and LonTalk controllers and is listed as a BACnet Building Controller (B-BC) by BACnet Test Labs (BTL). Tracer SC supports Trane® Air-Fi™ Wireless, providing standard wireless BACnet over Zigbee™ building automation between Trane BACnet controllers and zone sensors.
	<p>Support for Trane® Air-Fi™ Wireless</p> <ul style="list-style-type: none"> Trane Air-Fi Wireless brings maximum flexibility to your building automation system. For contractors, it significantly simplifies building controls projects by minimizing the engineering, estimating and project management tasks associated with communication link. For building owners, it provides easier and more cost-effective controls upgrades and building expansion projects. Trane technology helps prepare your facilities for the future of building information. Trane Air-Fi Wireless runs BACnet protocol over ZigBee building automation standards. Trane Wireless COMM is the first HVAC manufacturer to be Zigbee Certified.

Tracer Building Automation System

From our industry-leading building automation systems to equipment controls and sensors, Trane offers a complete controls portfolio to enable you to operate buildings at peak energy and operational efficiency.

Trane controls are built on open, scalable platforms. They provide options to integrate with your existing equipment and controls, regardless of brand, and give you the latitude to easily expand into other systems within your building, multiple buildings and buildings you'll add in the future.

 Tools and Services	Enterprise 	Tracer ES 
	Building 	Tracer SC 
	Equipment 	Tracer UC family 
	Spaces 	Sensors 

Tracer SC System Architecture

Tracer SC is at the heart of a Tracer building automation system. Tracer SC provides a web-based front end for your facility that can be accessed with most PCs, tablets and smart phones. Tracer SC includes powerful, factory-engineered applications that are designed to provide the perfect balance of energy efficiency and user comfort. Tracer SC communicates with a variety of Trane and non-Trane controllers using open, standard protocols, including BACnet and LonTalk. A diagram depicting the high-level system architecture is shown in Figure 1.

Figure 1. Tracer building automation system structure

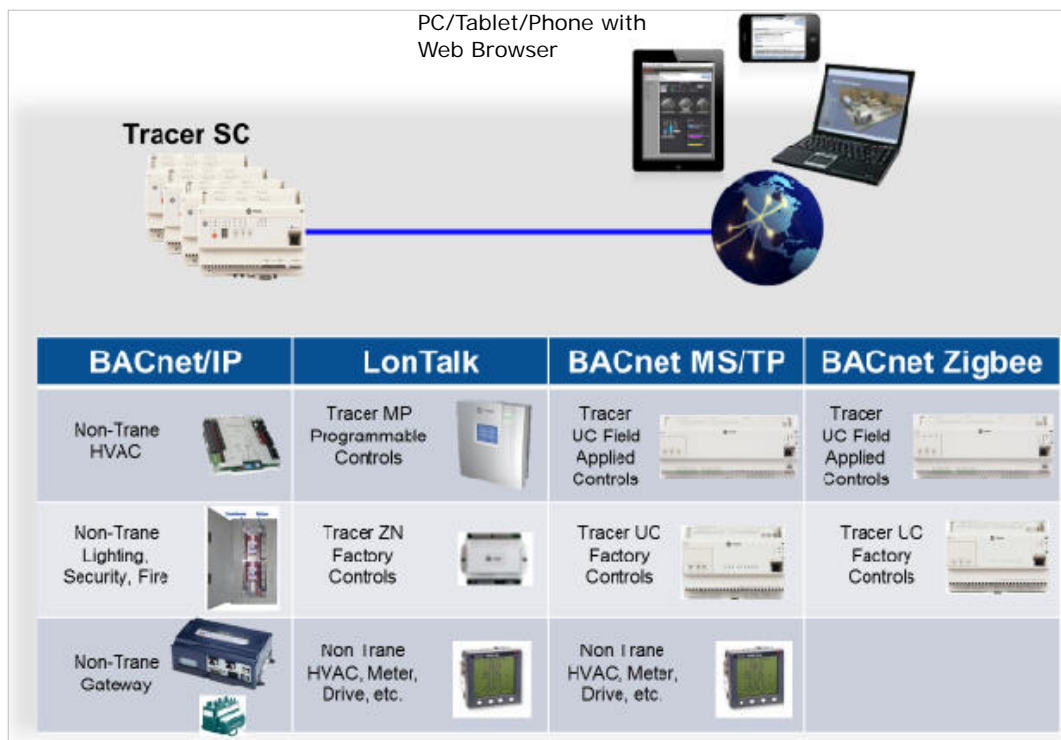



BAS R'newal™ Program

BAS R'newal is a new Trane building control systems upgrade program that helps customers transition to our current Tracer SC system. The program makes it easier to upgrade existing installed Tracer systems and non-Trane systems to the latest technologies including web-access, mobile access, intuitive user interfaces, and advanced features enabled by Trane Intelligent Services (TIS). The BAS R'newal program is enabled by Tracer Communication Bridges, the details of which can be found in the following section.

Find out more about BAS R'newal at http://www.trane.com/commercial/north-america/us/en/services/upgrade-improve/r_newal_programs.html.

Tracer® Communication Bridges

Tracer® Communications Bridges integrate legacy control products into current Tracer systems for monitoring and control purposes. See [Figure 2, p. 9](#) for a Tracer SC configuration that includes Tracer communication bridges.

Tracer Communications Bridges use legacy communications protocols to access points stored in previous-generation field-level controllers. The Bridges then convert the points to BACnet objects and properties, which makes them available for system use through the BACnet/IP communications protocol.

Comm2 to BACnet/IP

This bridge is used to integrate up to three UCP1-controlled chillers (CenTraVac and Series-R) into Tracer systems for monitoring and control purposes. For more information, refer to the "*Comm2 to BACnet/IP Product Data Sheet*," *BAS-PRC070*.

Comm3/4 to Tracer SC (enables the BAS R'newal program)

This bridge enables Comm3 and Comm4 devices to be integrated into Tracer SC systems, similar to current generation devices. The latest features and capabilities of Tracer SC can be accessed without needing to replace the existing Comm3 and Comm4 devices. For more information, refer to the "*Comm 3/4 to Tracer SC Product Data Sheet*," *BAS-PRC084*.

N2 to BACnet/IP (enables the BAS R'newal program)

This bridge integrates Johnson Controls, Inc., N2 communicating controllers into Trane Tracer control systems. The N2 Bridge converts the N2 controllers into virtual BACnet devices for easy integration into Tracer SC. For more information, refer to the "*N2 to BACnet/IP Product Data Sheet*," *BAS-PRC082*.

Tracer SC Facilities

A Tracer SC facility is defined as one Application SC and one or more associated Base SCs. A single building or site can contain more than one facility. See [Figure 2](#) for an example of an SC facility configuration.

The following attributes apply to Tracer SC facilities:

- A Tracer SC facility is limited to one Application SC.
- A Tracer SC facility has one or more Base SCs.
- A Tracer SC facility can support a maximum 240 devices.
- A Tracer SC facility may be limited to 120 devices depending on the communications involved (see the following table for device capability).

Device Capability

Communication Type	Single SC	Multi SC
Air-Fi™ Wireless	Up to 120 devices	Up to 240 devices
BACnet/MSTP	Up to 120 devices	Up to 240 devices
BACnet/IP	Up to 240 devices	Up to 240 devices
COMM 3/4/LON (individual or any combination)	Up to 120 devices	Up to 120 devices

Figure 2. Example of a single SC facility configuration

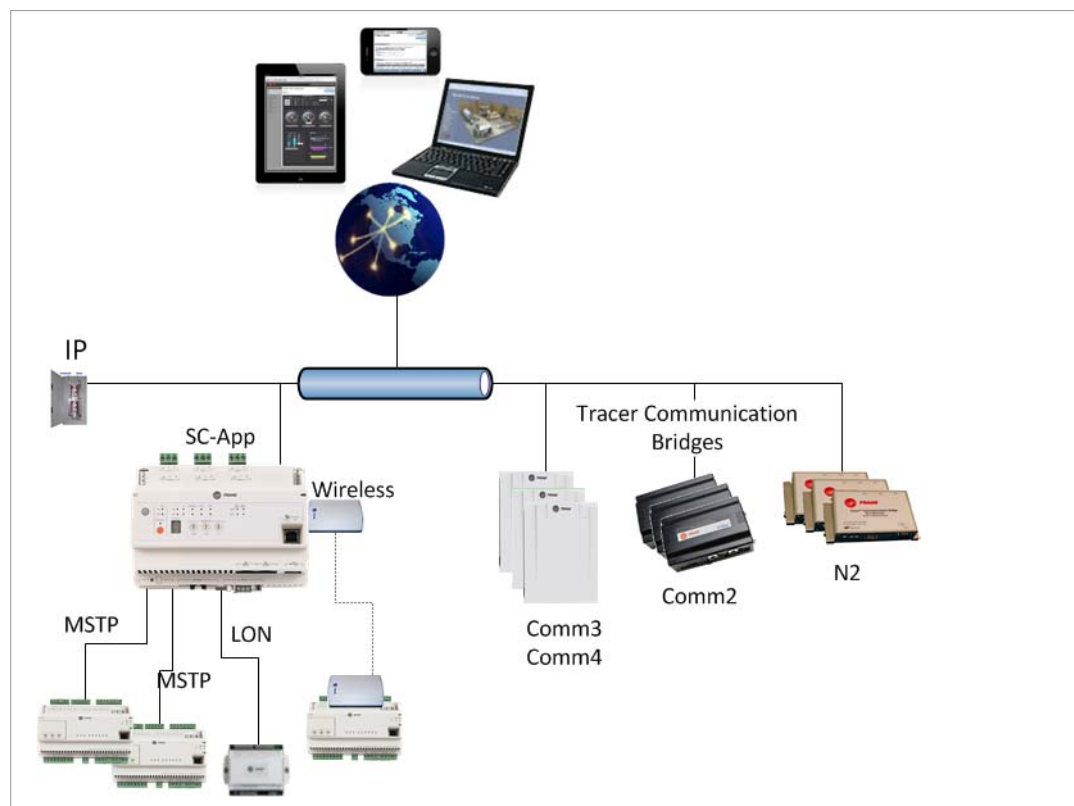

User Interface

The Tracer SC user interface provides an easy way for building operators to set up, operate, and modify a building automation system. The home page (Figure 3) contains system status information and links to navigate to all areas of the system.

The main features of the user interface are described in this section.

Figure 3. Tracer SC user interface

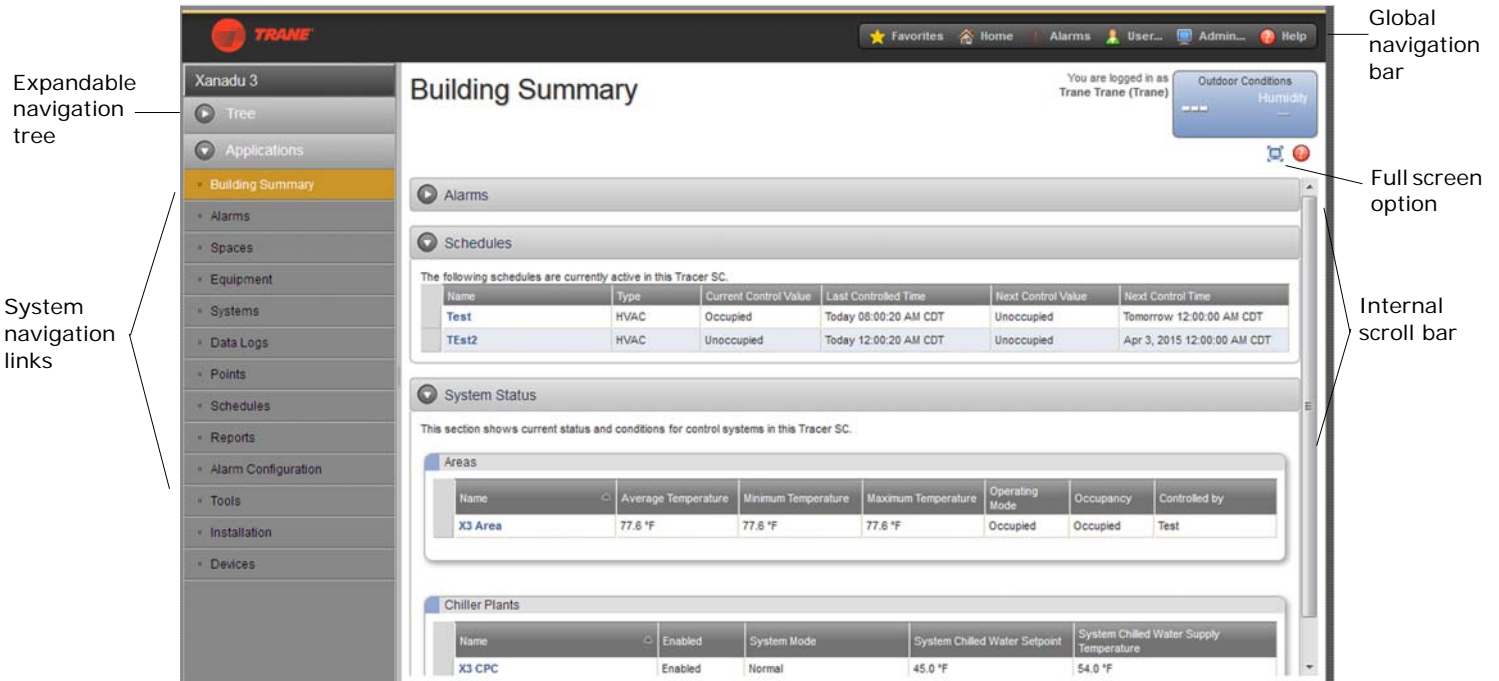

Alarms

Events are occurrences that are detected by a Tracer building automation system. They can include diagnostics and critical operating conditions, as well as routine procedures.

An event that is triggered by the detection of an abnormal or critical operating condition is generally considered to be an alarm. If a critical alarm exists, an alarm icon flashes in the global navigation bar, which remains visible in the right corner of every page of the user interface.

When the system detects an event, data about the event appears in a log on the Alarms page (Figure 4, p. 11). The data displayed in the log includes when and where the event occurred and whether the operator is required to acknowledge it. An operator can also use the log to add comments about events. Column headings can be used to sort and filter events. They can also be removed or exported from the log.

Figure 4. Alarms log

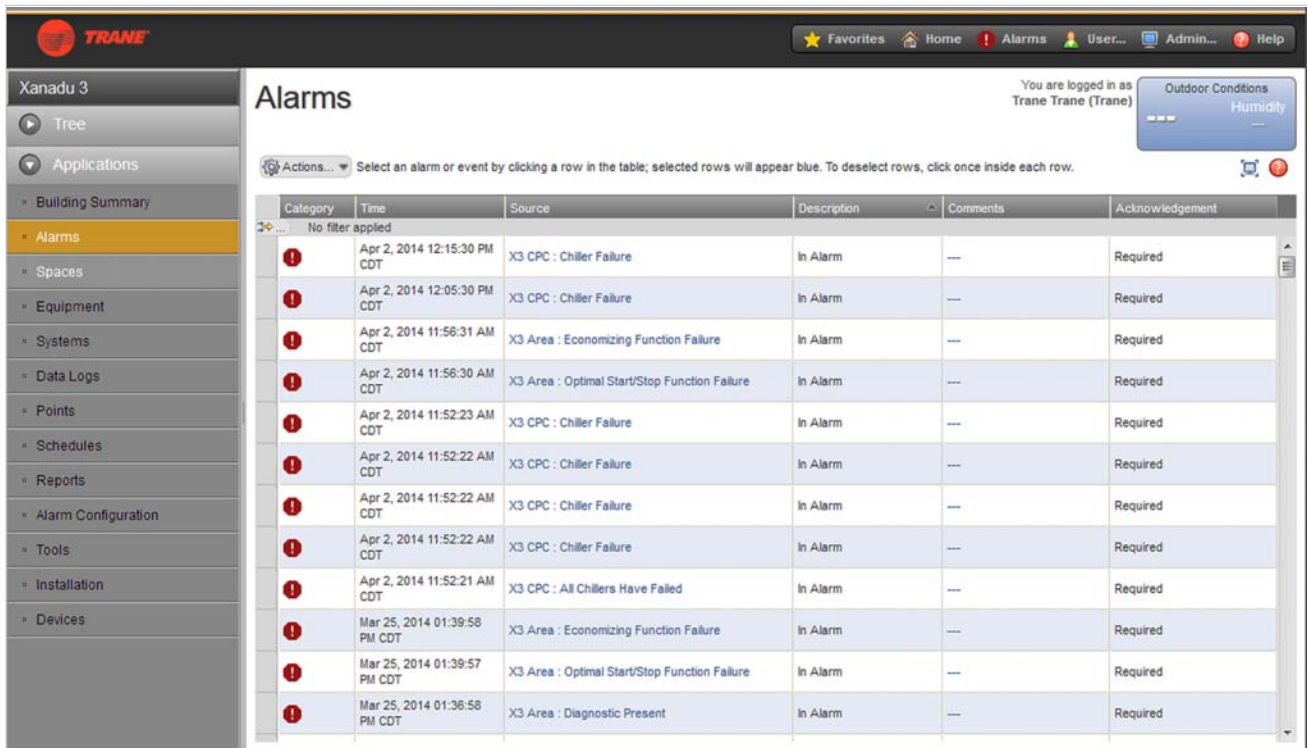

Category	Time	Source	Description	Comments	Acknowledgement
	No filter applied				
!	Apr 2, 2014 12:15:30 PM CDT	X3 CPC : Chiller Failure	In Alarm	---	Required
!	Apr 2, 2014 12:05:30 PM CDT	X3 CPC : Chiller Failure	In Alarm	---	Required
!	Apr 2, 2014 11:56:31 AM CDT	X3 Area : Economizing Function Failure	In Alarm	---	Required
!	Apr 2, 2014 11:56:30 AM CDT	X3 Area : Optimal Start/Stop Function Failure	In Alarm	---	Required
!	Apr 2, 2014 11:52:23 AM CDT	X3 CPC : Chiller Failure	In Alarm	---	Required
!	Apr 2, 2014 11:52:22 AM CDT	X3 CPC : Chiller Failure	In Alarm	---	Required
!	Apr 2, 2014 11:52:22 AM CDT	X3 CPC : Chiller Failure	In Alarm	---	Required
!	Apr 2, 2014 11:52:22 AM CDT	X3 CPC : Chiller Failure	In Alarm	---	Required
!	Apr 2, 2014 11:52:21 AM CDT	X3 CPC : All Chillers Have Failed	In Alarm	---	Required
!	Mar 25, 2014 01:39:58 PM CDT	X3 Area : Economizing Function Failure	In Alarm	---	Required
!	Mar 25, 2014 01:39:57 PM CDT	X3 Area : Optimal Start/Stop Function Failure	In Alarm	---	Required
!	Mar 25, 2014 01:36:58 PM CDT	X3 Area : Diagnostic Present	In Alarm	---	Required

The alarm handling capabilities of Tracer SC allow users to receive, view, acknowledge, and make comments on building alarms.

Users can categorize alarms to determine how they appear in the Alarm log. A category is assigned to one of 255 priorities. In previous versions of Tracer SC, alarm categories were limited to four types: Severe, Critical, Advisory, and Information. As of Tracer SC version 4.0, users can create additional categories and select an accompanying icon. Benefits of customizing alarm categories include the ability to send a specific alarm to a specific person, and to differentiate critical equipment alarms from others.

Data Logs

Data logs, also referred to as trends, allow users to produce a variety of data samples at defined intervals to show the historical and current status of the facility. Data logs record, in real-time, the value of a data point in the system and the time at which the value was recorded.

Data logs can be viewed in real-time, or at a later time. They can also be printed and saved. With the proper security access, system users can configure (create, delete, and update) and manage (clear, enable, and disable) data logs in the system. (See [Figure 5](#), p. 12 for an example of a data log.)

Figure 5. Data Logs example



Schedules

Scheduling is one of a facility's most important energy-saving strategies. It ensures that equipment runs only when needed. Use schedules to:

- Keep equipment running at minimal energy-use levels on weekends and holidays
- Create exceptions to the standard schedule
- Perform optimal start and stop of equipment to optimize energy use while maintaining comfort requirements
- Change setpoints at specific times of day

From the home page, you can select:

- All Schedules, which shows all schedules in the system
- Active Schedules, which shows only the active schedules in the system

Figure 6, p. 13 shows an example of an All Schedules page.

Figure 6. Schedules

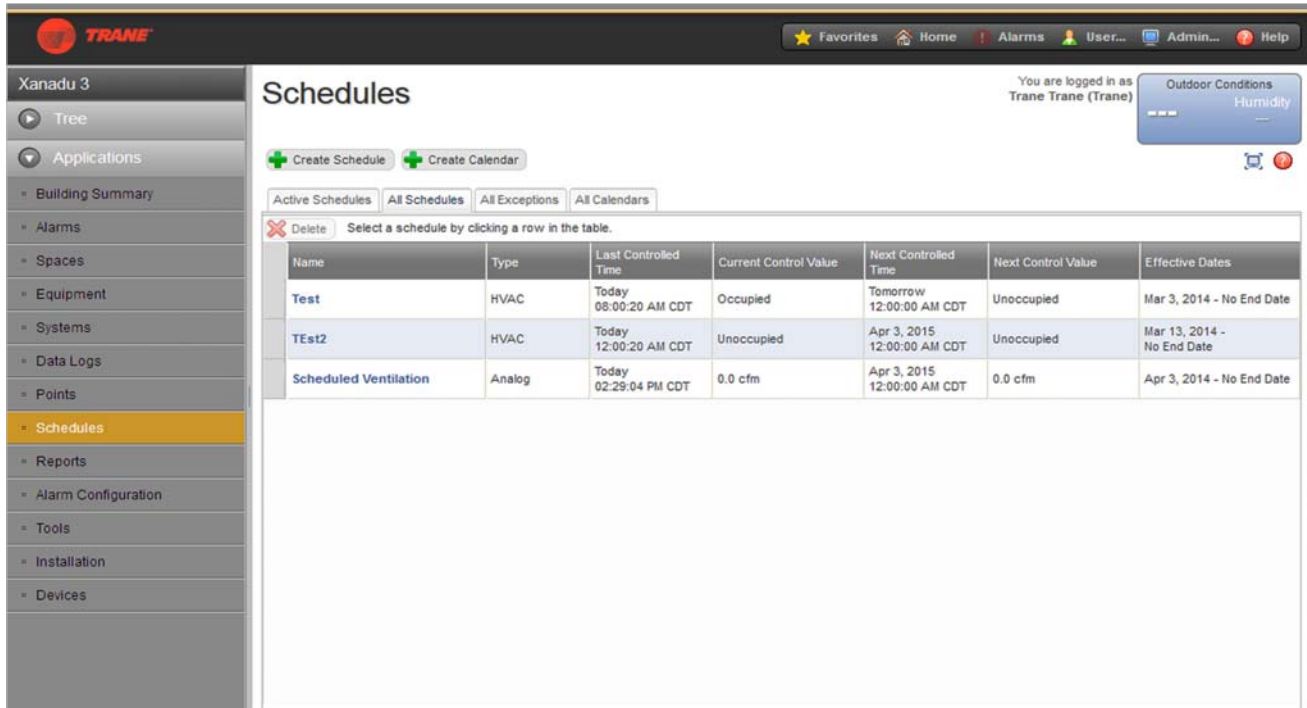

Overrides

A typical challenge that facility managers have is maintaining the balance between automatic and manual system control. Tracer SC provides multiple methods of overriding equipment, applications, and points while also ensuring that the proper balance of automatic and manual system control is kept. These methods include:

Permanent Overrides

The most typical use of a permanent override is through applications. Tracer SC provides the ability to determine which user or application has performed an override to quickly determine who has overridden a setpoint.

Temporary Overrides

A common challenge in facilities is inadvertent overrides. Tracer SC provides a default override option for users, which allows an override to expire after a period of time. This ensures that temporary overrides do not inadvertently become permanent overrides.

All items in Override Report

It can be difficult to track down overrides that have become permanent and are causing a facility to act differently than a facility manager expects. Tracer SC includes a standard report that allows a user to quickly identify all points within the system that have been overridden. See [Figure 7, p. 14](#).

Figure 7. All Items in Override Report

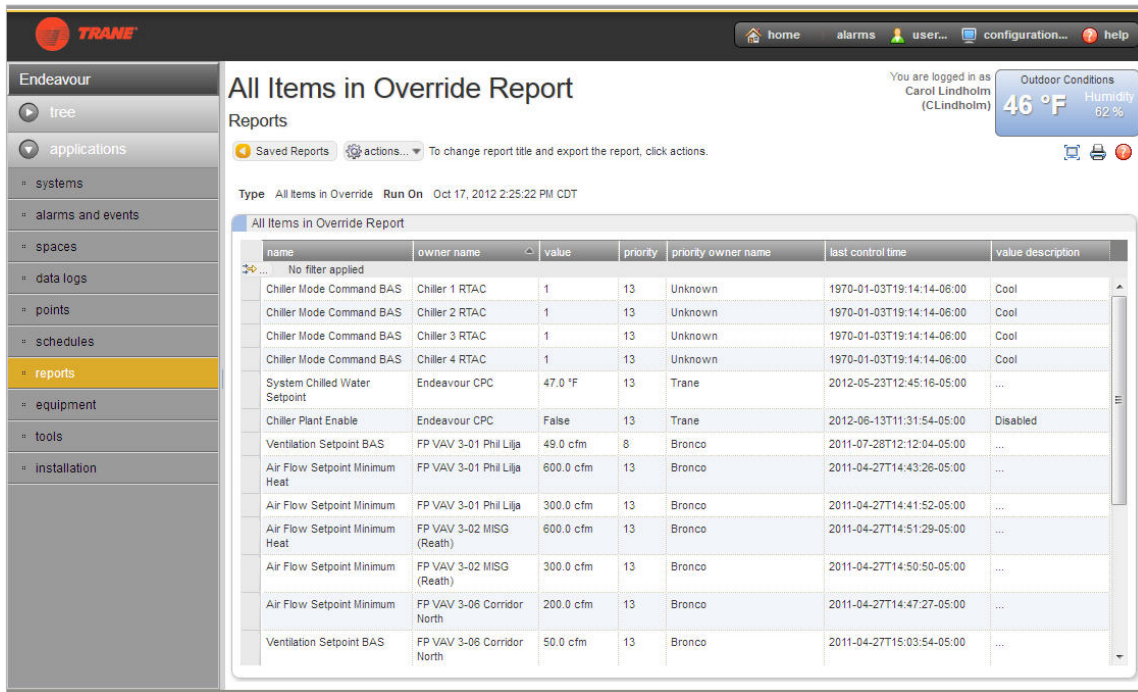

Reports

Standard reports for Trane equipment are available from Tracer SC. These reports provide a valuable source of data that can be used for record-keeping and troubleshooting.

Report types include:

- Site reports
- VAS commissioning reports
- Points reports
- Chiller reports

Report features include:

- Scheduling reports to run during specific date periods and run frequencies
- Specifying file storage options for scheduled reports
- Exporting reports to save to your PC as CSV, HTML, or PDF files
- Editing scheduled reports

See [Figure 8, p. 15](#).

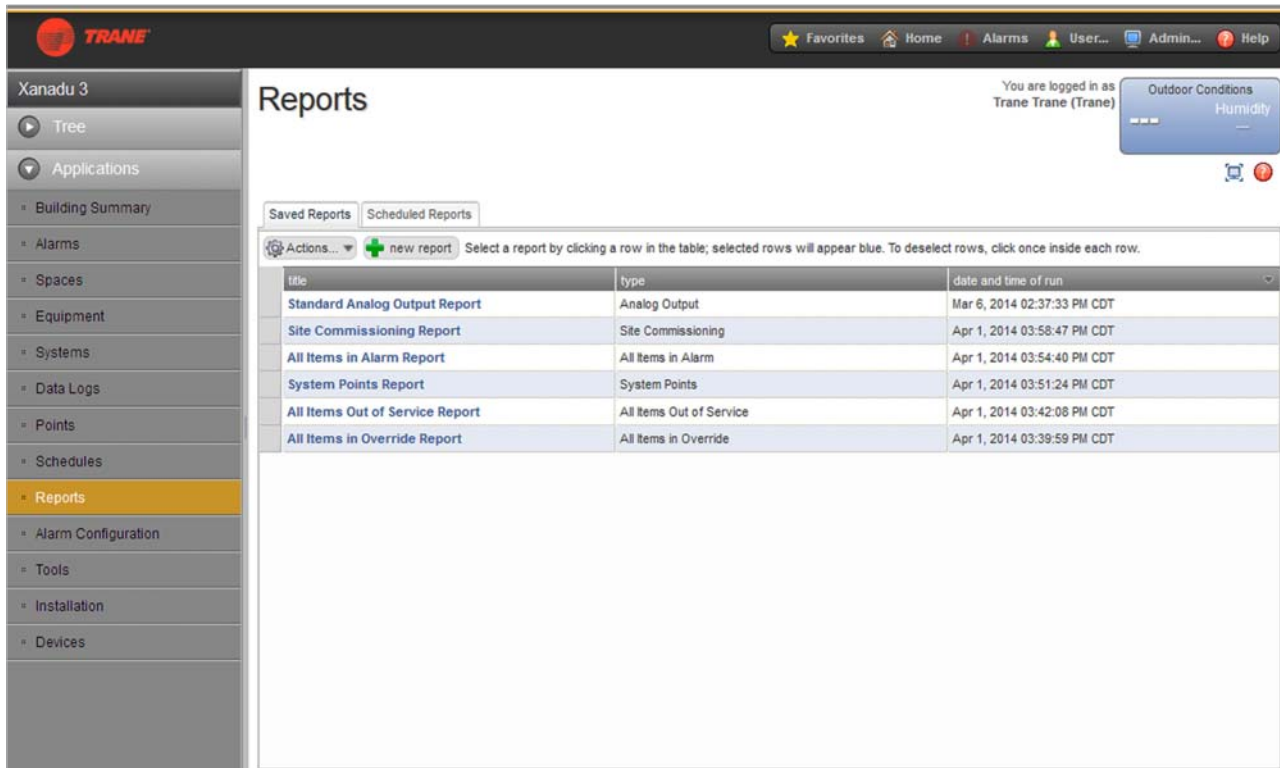
Figure 8. Reports

Graphics and the Tracer Graphics Editor

With the Tracer Graphics Editor (TGE), available through the TracerTU service tool, users can create, edit, and publish graphics for use on Tracer SC. Graphics on the Tracer SC monitor and control building equipment and applications. They can display data related to climate, lighting, and other controllable operations. They can be used to change setpoints and to override equipment operation.

TGE can be used to align graphical elements, determine which elements appear on top, and perform cut, copy, and paste functions.

Graphics can include:

- Any data that is available in the system as a numerical or text value
- Analog values that can change colors if they deviate from a desired value
- Multiple graphic images in JPEG, GIF, and animated GIF formats
- Visual elements from the building, such as floor plans or exterior views from CAD drawings
- Digital photography in JPG and GIF formats
- Animated images to represent binary and analog values
- Target buttons that provide links to related sources
- User controls including push buttons, check boxes, drop-down list boxes, and entry fields

User Interface

Graphics can be grouped in a logical way to simulate navigation through the building automation system. See [Figure 9](#), [Figure 10](#), and [Figure 11](#) as examples.

Figure 9. Home page showing graphic of building exterior (example 1)

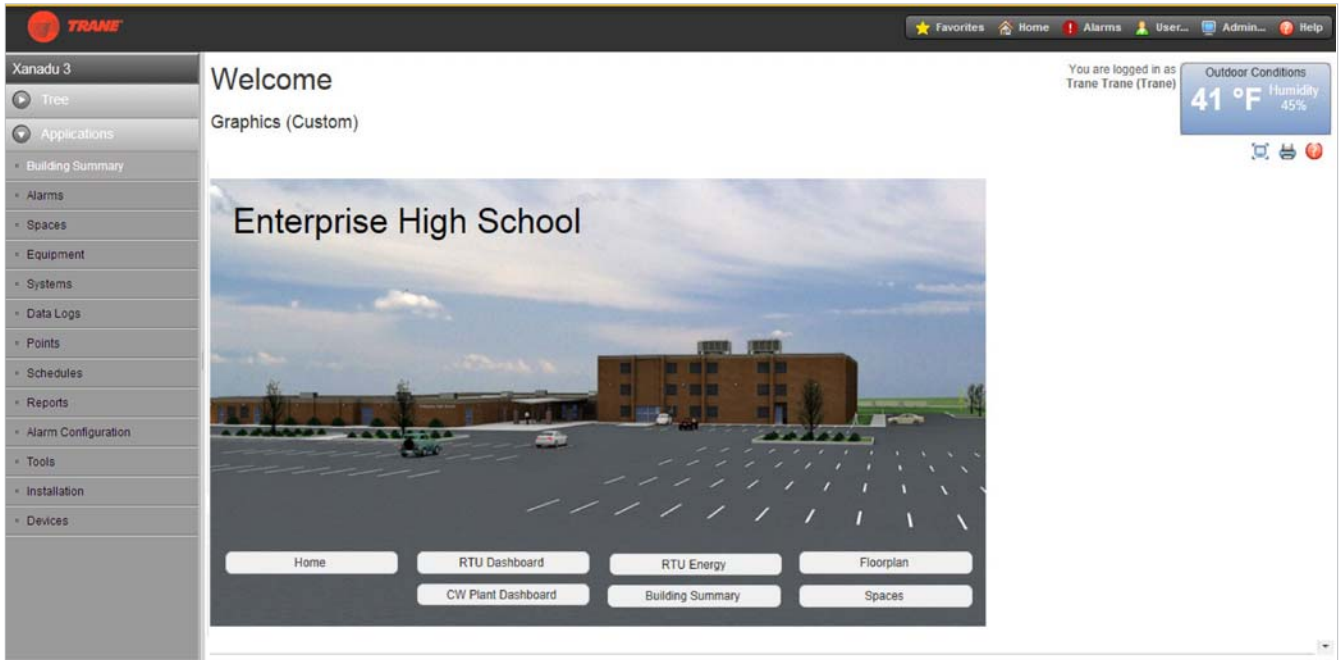

Figure 10. Home page with floor plan graphic (example 2)

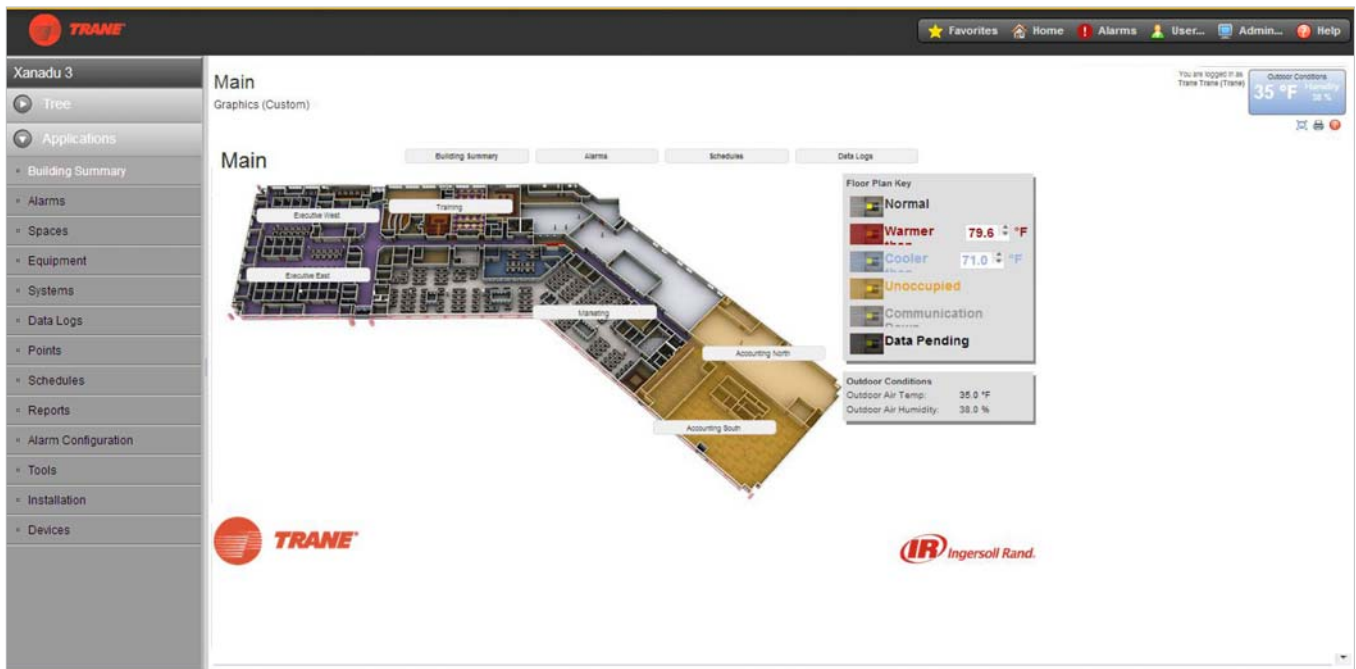
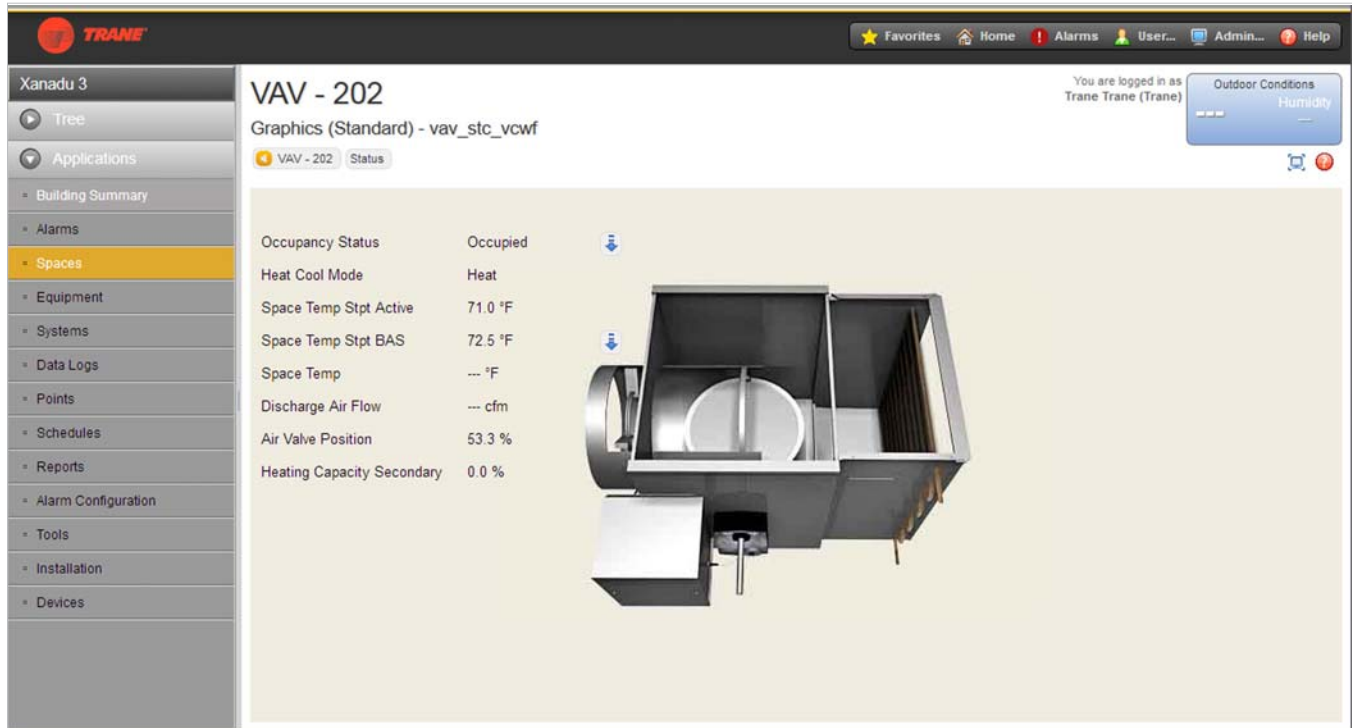

Figure 11. Equipment status graphic (example 3)



Graphical and Bindable Widgets

New in Tracer SC V4.1 is the option to incorporate graphical and bindable widgets into Tracer SC custom pages. Graphical widget components provide a visual representation of an analog process such as the current temperature or the current level of a water tank. Bindable widgets provide control and display of system controls and states in a simplified way. The following figure provides an example of each.

Figure 12. Widget examples

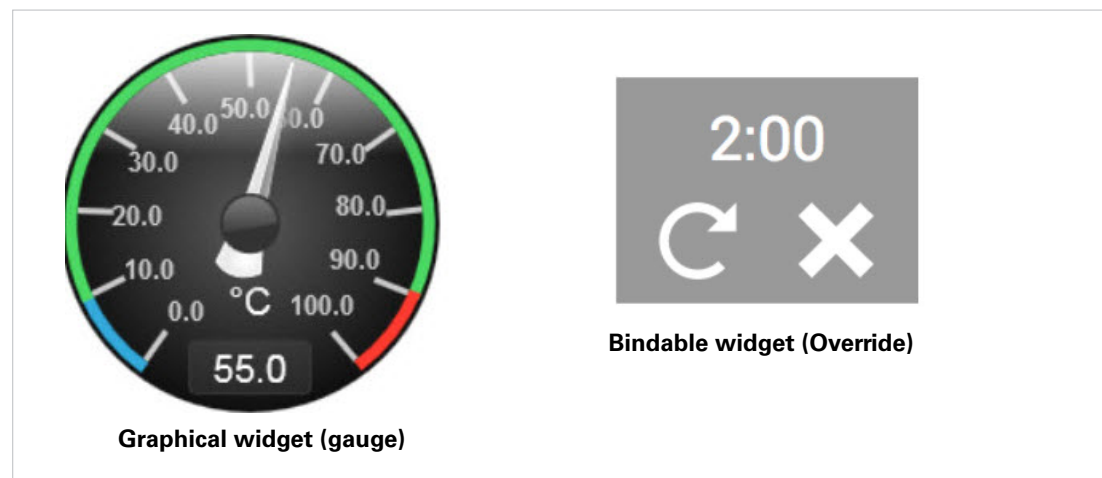

Navigation Tree

The navigation tree contains the logically ordered and grouped content of all the elements of your HVAC system. The navigation tree populates automatically when spaces, systems, points, and equipment are installed. A navigation tree provides an alternate way to navigate through the user interface (Figure 13).

The navigation tree consists of nodes, display text, and icons. You build the tree by choosing display text for nodes, arranging the nodes, and assigning associated graphics to them. The graphics represent equipment and areas of the facility.

Figure 13. Navigation tree example

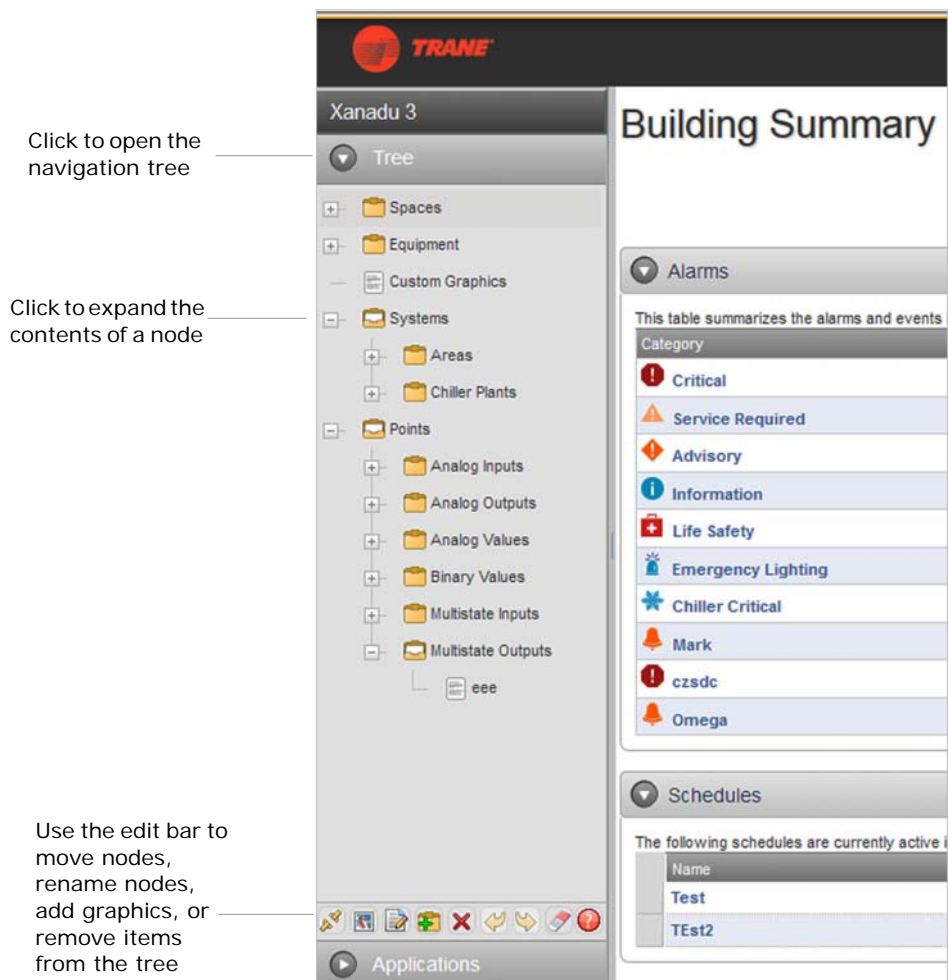

User Security

A sophisticated password system protects a Tracer system from unauthorized access. Operators are assigned a role, which defines their access rights. Operators have access only to those features that are defined in their roles. Several predefined roles can be selected from the Tracer SC interface and roles can also be customized. An operator with administrative-level security can manage users and roles and has the ability to reset passwords.

System Control

Tracer SC includes a powerful system control engine. Every Tracer SC ships with several factory engineered HVAC applications, support for Trane Earthwise™ Systems, and a powerful custom graphical programming language.

Area Application

The Area application coordinates groups of equipment that represent the tenant or occupant organization within a building, which allows for standard calculations/functions and a simplified user interaction with the facility. The Area application allows users to assign unit controllers, binary outputs, and binary values as members of a common area. The area application can be configured to use multiple algorithms, along with area temperatures and humidity inputs, to make an economizing decision.

The Area application also supports:

- Optimal start/stop
- Humidity pulldown
- Night purge
- Unoccupied heating/cooling setpoints
- Unoccupied humidify/dehumidify
- Timed override functions

Additionally, the Area application allows users to efficiently perform a single operation, such as changing a setpoint, creating a schedule, performing an override, and apply it to all members of the area. For more information, see the *"Air Systems for Tracer SC Applications Guide"*, BAS-APG007.

Variable Air Systems (VAS)

The Variable-Air-Volume Air System (VAS) coordinates the control of air handlers, rooftop units, and variable air volume terminal units. The Tracer SC VAS includes valuable tools to help manage tasks that were previously problematic and time consuming, such as:

- Determining Heat/Cool mode for changeover systems
- Coordinating AHU and VAV box operation
- Commissioning VAV boxes
- Scheduling common spaces
- Optimizing ventilation
- Optimizing duct static pressure

For more information, see the *"Air Systems for Tracer SC Applications Guide"*, BAS-APG007.

Chilled Plant Control (CPC)

The Chiller Plant Control (CPC) application permits users to configure a chiller plant for optimal efficiency and reliability, and provides a means for monitoring and controlling the daily operation. Depending upon the many possible chiller plant configurations and design differences, the CPC application can do the following:

- Provide overall chiller plant status information and alarms to local and remote Tracer SC users
- Enable or disable chiller plants
- Start, stop, and monitor the status of system chilled water pumps
- Calculate individual chilled water setpoints for individual chillers in series chiller plants

System Control

- Request when chillers are added or subtracted according to building load requirements and user-specified add and subtract logic
- Rotate chillers according to user-defined intervals
- Remove chillers from the rotation in the event

For more information, see the “Chiller Plant Control for Tracer SC Application Guide”, BAS-APG012.

Trane EarthWise™ Systems

For any building owner concerned with energy, indoor air quality, and the environment, Trane's EarthWise Systems represent a design philosophy whose time has come. EarthWise and EarthWise Elite Systems, by definition, provide documented sustainability of high efficiency and low emissions over the entire lifetime of the building.

Trane EarthWise Systems include:

- Low Flow, Low Temperature CentraVac™ Chilled Water Systems
- Ice Enhanced, Air-Cooled Chiller Plant
- Intelligent Variable Air System for chilled-water applications
- Intelligent Variable Air System for IntelliPak™ rooftop applications
- Central Geothermal Systems

Find out more about EarthWise at <http://www.trane.com/commercial/north-america/us/en/products-systems/earthwise-systems.html>

Tracer Graphical Programming (TGP2)

Tracer Graphical Programming (TGP2) is a powerful graphical program that allows you to customize Tracer system applications. TGP2 routines are typically used for sequencing equipment, calculating setpoints and values, and performing shutdown sequences. See [Figure 14, p. 21](#) for an example.

Note: TGP2 is available through the Tracer TU service tool.

Figure 14. TGP2 example

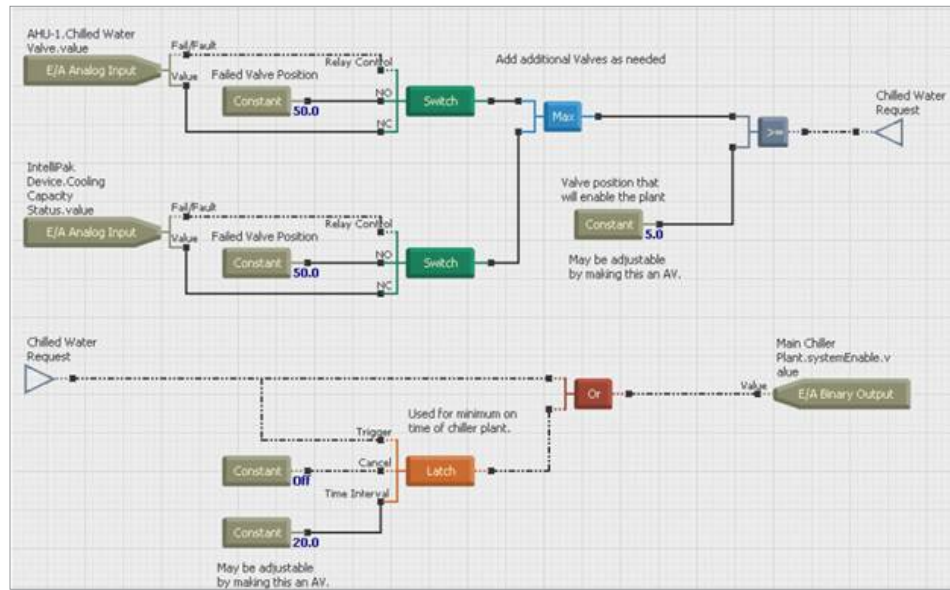



Unit Control

Unit controllers provide all necessary unit control functions. They operate associated unitary equipment, while ensuring that all built-in safety features are enabled and that diagnostics are issued.

Each controller is designed to operate in stand-alone mode. Therefore, if system control fails, unit operation can continue.

Unit controllers installed on a Tracer SC can be a combination of the following BACnet and LonTalk unit controllers:

BACnet (MS/TP) Unit Controllers Supported by Tracer SC

- Tracer UC210 unit controller for variable-air-volume (VAV) equipment
- Tracer UC400 unit controller for variable-air-volume (VAV) equipment
- Tracer UC400 unit controller for programmable equipment
- Tracer UC800/AdaptiView unit controller for CenTraVac chillers
- BCI-I: BACnet communications interface for IntelliPak system
- BCI-C: BACnet communications interface for chillers
- BCI-R: BACnet communications interface for ReliaTel
- Non-Trane BACnet (MS/TP) devices

BACnet/IP Unit Controllers Supported by Tracer SC

- Tracer UC600 Programmable controller
- Non-Trane BACnet/IP devices

Air-Fi Wireless Unit Controllers Supported by Tracer SC

- Tracer UC210 unit controller for variable-air-volume (VAV) equipment
- Tracer UC400 unit controller for variable-air-volume (VAV) equipment
- Tracer UC400 unit controller for programmable equipment
- Tracer UC600 unit controller for Air Handler (AHU) equipment
- Tracer UC600 unit controller for programmable equipment

LonTalk Unit Controllers Supported by Tracer SC

- Tracer AH540/541 air-handler controller
- Tracer MP501 multi-purpose controller
- Tracer MP503 input/output module
- Tracer MP580/581 programmable controller
- Tracer VV550/551 VAV controller
- Tracer ZN510/511 zone controller
- Tracer ZN517 unit controller
- Tracer ZN520/521 zone controller
- Tracer ZN523 zone controller
- Tracer ZN524 water-source heat pump unit controller
- Tracer ZN525 zone controller

- Tracer CH530 chiller controller
- Tracer CH532 chiller controller
- LCI-C: LonTalk communications interface for chillers
- LCI-I: LonTalk communications interface for IntelliPak systems
- LCI-R: LonTalk communications interface for ReliaTel systems
- Non-Trane LonTalk devices using SCC, DAC, and chiller profiles, devices that support LonTalk standard network generic variables, and devices with Standard Network Variable Types (SNVTs)

Trane Legacy Unit Controllers (Comm3/4) Supported by Tracer SC

Note: *The following devices are supported through the use of Legacy Comm Bridge.*

- Variable Air Volume (VAV I, II, III, IV)
- IntelliPak
- Voyager
- Commercial Self-Contained (CSC)
- Thermostat Control Module (TCM)
- Programmable Control Module (PCM)
- Universal Programmable Control Module (UPCM)
- Terminal Unit Controller (TUC)
- Centrifugal Chillers (UCP2)
- Helical Rotary Chillers (UCP2)
- CGX Chillers
- Series-R Chillers (RTA/RTW)



Resources

The following resources are available for managing Tracer building automation systems:

Tracer SC Installation, setup, and operation

- Tracer SC System Controller Installation and Setup Guide (BAS-SVX31)
- Tracer SC online help
- Tracer SC Installation Instructions (X39641154)
- BACnet Wiring Best Practices and Troubleshooting (BAS-SVX51)

Programming

- Tracer Graphical Programming (TGP2) Editor
- Tracer Graphical Programming (TGP2) Application Guide (BAS-APG008) and online help
- Tracer UC400/UC600 with Tracer SC Programming Guide (BAS-SVP06)

HVAC applications

- Tracer SC Air Systems Application Guide (BAS-APG007)
- Tracer SC Chiller Plant Control Application Guide (BAS-APG012)

Service tools

- TracerTU ServiceTool Getting Started Guide (TTU-SVN01) and online help
- Rover Operation and Setup Guide (EMTX-SVX01) and online help

Tracer Summit (for Legacy Comm Bridge)

- Tracer Summit Daily Operations Guide (BMTX-SVU01)

Graphics Tools

- Tracer Graphics Editor (TGE) User Guide (BAS-SVU06)
- Working with Standard Graphic Templates (BAS-SVU15)
- Offline Graphics Creation (BAS-SVU16-EN)
- Centralized Services

Software updates

- TracerTU ServiceTool Getting Started Guide (TTU-SVN01)

Web sites

- MyTraneControls.com: A free Web site designed to assist Tracer building automation system owners and operators.

Tracer BAS training courses

- The Trane College of Building Automation offers a comprehensive portfolio of technical courses on the operation, installation, and programming of Tracer building automation systems. Refer to <http://www.trane.com/commercial/north-america/us/en/products-systems/education-training/training/controls-and-automation.html>.

Service, maintenance, troubleshooting

In addition to the resources listed above:

- Trane Product Support
- Warranty information

Specifications

This section contains specifications for Tracer SC system controllers and for Tracer building automation systems.

Table 1. Tracer SC specifications

Client Software Requirements	PC or Mac	Microsoft® Windows 7, 8: <ul style="list-style-type: none"> • Internet Explorer™ version 9.0 or higher • Mozilla Firefox® latest version • Google Chrome™ latest version Mac® OS : <ul style="list-style-type: none"> • Mozilla Firefox® latest version • Google Chrome™ latest version • Safari® latest version
	Tablet/Phone	iOS (iPad®/ iPhone®) latest version: <ul style="list-style-type: none"> • Safari (latest version) • Mozilla FireFox (latest version) • Google Chrome (latest version) Android (latest version) <ul style="list-style-type: none"> • Google Chrome (latest version) • Mozilla FireFox (latest version) Windows Mobile – (latest version) <ul style="list-style-type: none"> • Stock browser only
	Concurrent Users	<ul style="list-style-type: none"> • Five
	Supported Languages	Up to four languages are supported per Tracer SC. <ul style="list-style-type: none"> • English • Chinese (Simplified/Traditional) • French • French Canadian • Portuguese (Brazil) • German • Indonesian • Japanese • Korean • Spanish (Latin America) • Thai • Polish • Arabic

Specifications

Table 1. Tracer SC specifications

Tracer SC system controller	Power requirements	From PM014 Power Supply: 24 Vdc @ 0.3A; 14VA max (PM014 input VA)
	Operating environment	<ul style="list-style-type: none"> • Temperature: From –40°F to 122°F (–40°C to 50°C) • Relative humidity: From 10% to 90%, non-condensing
	Storage environment	<ul style="list-style-type: none"> • Temperature: From –40°F to 158°F (–40°C to 70°C) • Relative humidity: From 5% to 95%, non-condensing
	Agency Listings	<p>UL:</p> <ul style="list-style-type: none"> • UL-864/UUKL listed (when installed and programmed in accordance with the Engineered Smoke Control System Application Guide, BAS-APG019-EN) • UL-916-PAZX – energy management • CUL-C22.2-signal devices – Canada <p>FCC:</p> <ul style="list-style-type: none"> • FCC part 15, Class A CE <p>CE:</p> <ul style="list-style-type: none"> • Emissions EN61326:1998 Class B • Immunity EN61326:1998 • Commercial Safety EN61010-1:2001 <p>ISO:</p> <ul style="list-style-type: none"> • 9001:2008
	Processor	PowerPC405 Core
	Memory	<ul style="list-style-type: none"> • FLASH 400 MB • SDRAM 256 MB
	Battery	<ul style="list-style-type: none"> • No battery required. The clock is maintained for a minimum of three days by the super capacitor. All other programs are backed up by nonvolatile memory.
Protocol Communication	BACnet	<p>Tracer building automation systems communicates with BACnet devices that support:</p> <ul style="list-style-type: none"> • Communications based on the BACnet ASHRAE/ANSI 2012 standard • ENV-1805-1/ENV-13321-1 • 10BASE-T/100BASE-TX dedicated Ethernet (ISO/IEC 8802-3) or Transmission Control Protocol/Internet Protocol (TCP/IP) compatible network <p>Tracer SC is listed by BACnet Test Labs (BTL) as a BACnet Building Controller (B-BC). Listing information can be found at: http://www.bacnetinternational.net</p>
	LonTalk	<p>Tracer building automation systems communicates with LonTalk devices that support:</p> <ul style="list-style-type: none"> • Communications based on the EIA-709.1 (LonTalk) standard • LonTalk standard network variable types (SNVTs) • FTT-10A or FT-X1 transceivers • Twisted-pair physical media (Level 4 wiring)
	Device Limits	<p>Tracer SC facility (Combination of all protocols)</p> <ul style="list-style-type: none"> • Up to 240 devices <p>BACnet (Per link/Per facility)</p> <ul style="list-style-type: none"> • Tracer UC200 Series - 60/240 • Tracer UC400 Series - 60/240 • Tracer UC600 Series- 10/20 • Tracer UC800 Series - 60/240 • BCI Series - 60/240 • Trane Communicating Thermostats - 60/120 • Non-Trane BACnet - 32/240 <p>LonTalk (Per link/Per facility)</p> <ul style="list-style-type: none"> • AH Series - 120/120 • CH Series - 120/120 • VV Series - 120/120 • ZN Series - 120/120 • MP503 - 120/120 • MP580 - 20/20 • Trane Communicating Thermostats - 120/120 • Non-Trane LON - 120/120 <p>Air-Fi Wireless (Per network/per facility)</p> <ul style="list-style-type: none"> • WCI - 30/240

Table 1. Tracer SC specifications

Medium Enclosure (optional)	NEMA Type	NEMA-1
	Weight	14 lb. (6.5 kg)
	Mounting	Wall-mounted with #10 (5 mm) screws and #10 wall anchors. Mounting surface must be able to support 60 lb. (28 kg)
Large Enclosure (optional)	NEMA Type	NEMA-1
	Weight	50 lb. (23.0 kg)
	Mounting	Wall-mounted with #10 (5 mm) screws and #10 wall anchors. Mounting surface must be able to support 120 lb. (56 kg)

Hardware Components

The SC system controller itself and additional hardware options are described in this section.

- Tracer SC system controller components
- Trane PM014 power supply module
- Tracer BACnet terminator
- Medium enclosure
- Large enclosure

Tracer SC System Controller

The Tracer SC system controller components are labeled in [Figure 15](#).

Figure 15. Tracer SC system controller components

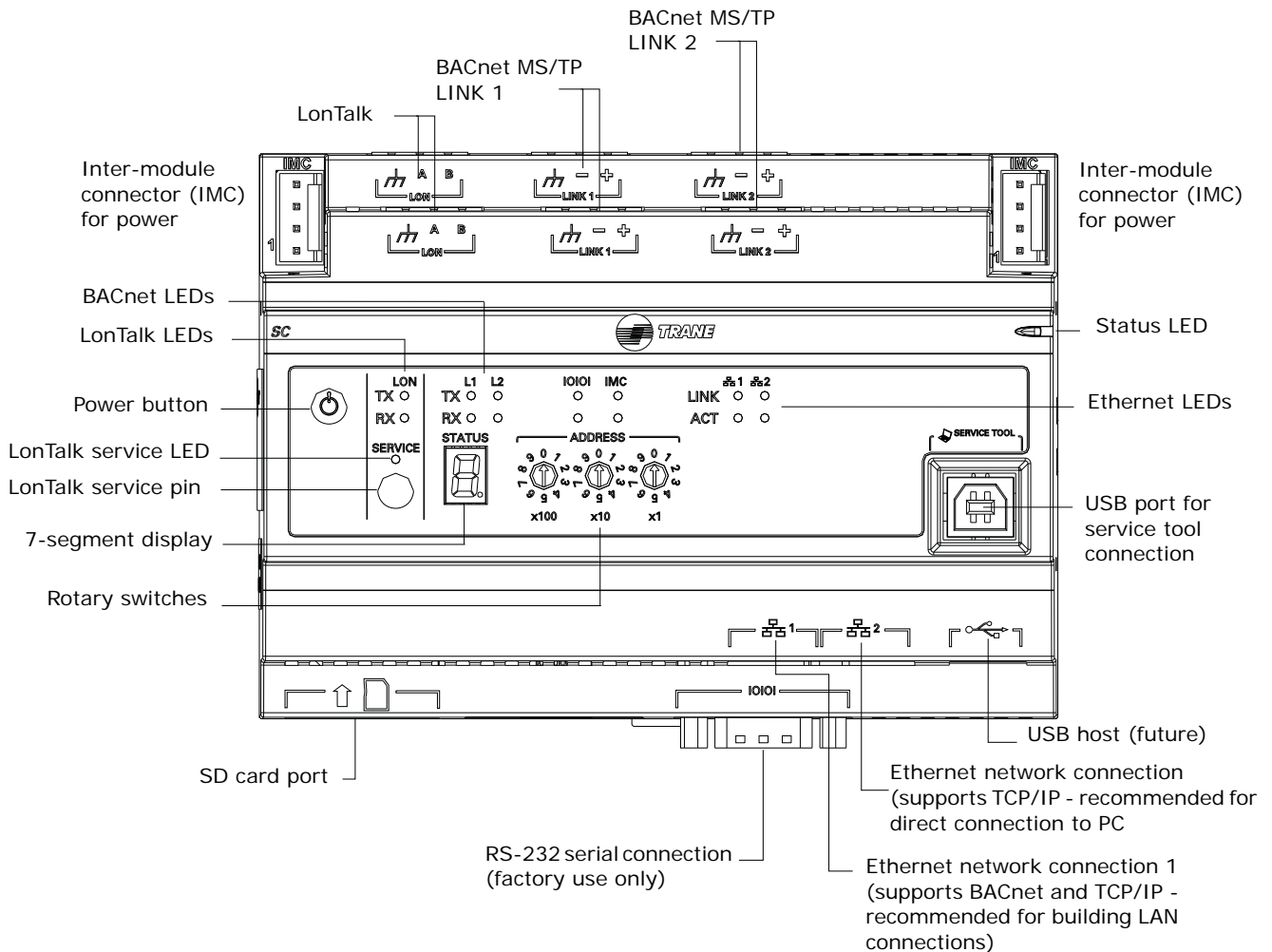

Dimensions

Figure 16. Tracer SC system controller dimensions

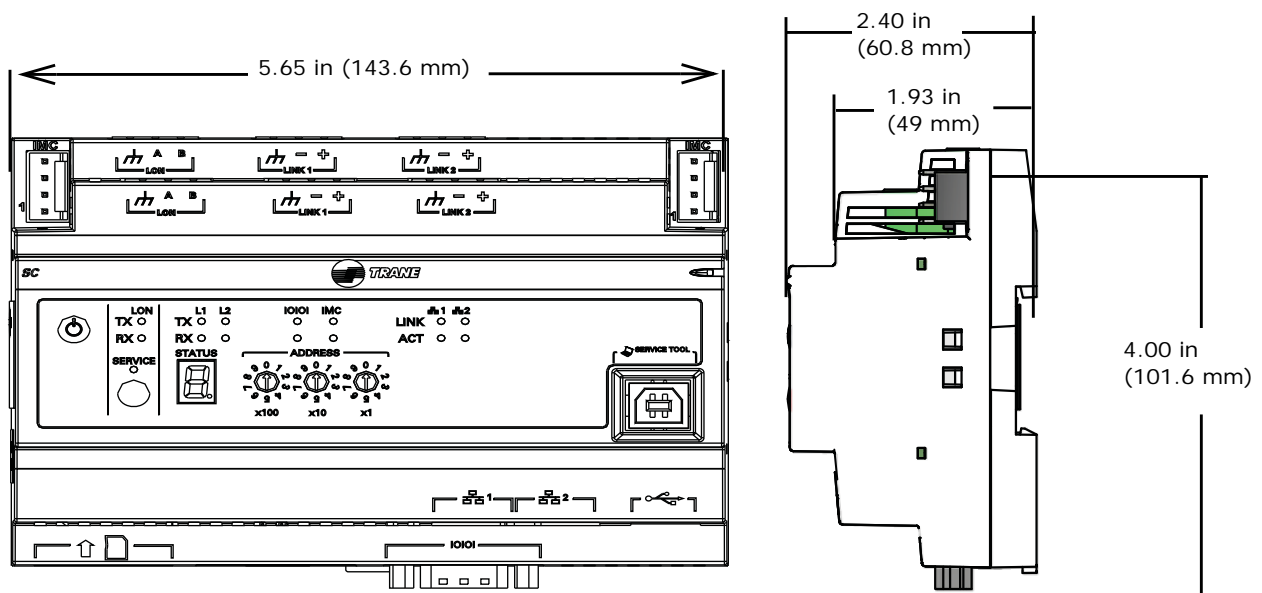

Trane PM014 Power Supply Module

The Trane PM014 power supply module provides 24 Vdc for Trane inter-module communication (IMC) buses (Figure 17, p. 29). IMC buses are used in components of Trane building automation systems, including the Tracer SC system controller. Refer to the *“Power Supply Module Installation, Operation, and Troubleshooting Guide,” BAS-SVX33.*

Figure 17. PM014 power supply module (dimensions)

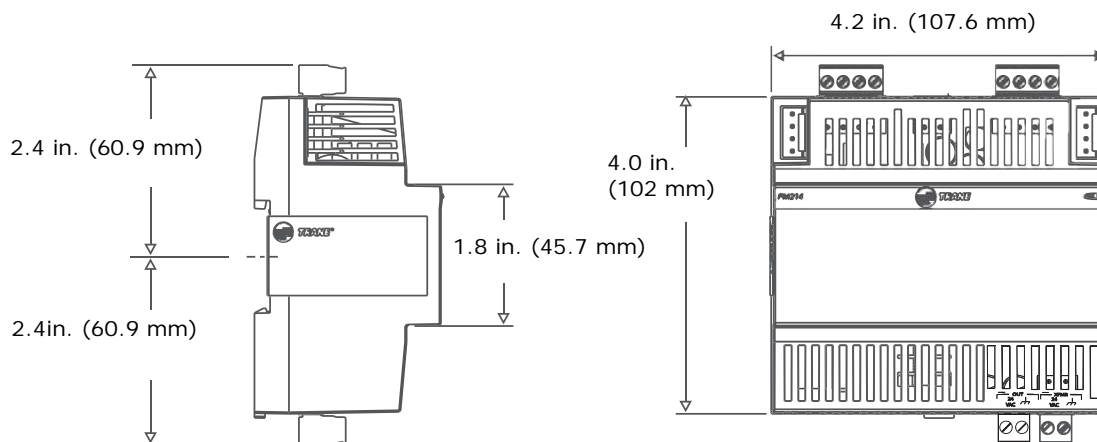

Tracer[®] BACnet[®] Terminator

A Tracer BACnet terminator (order no. X13651524-01) is placed at the end of each communication link in order to decrease communication signal degradation (Figure 18). Refer to the “BACnet Wiring Best Practices and Troubleshooting Guide,” BAS-SVX51.

Figure 18. BACnet terminator (wiring)

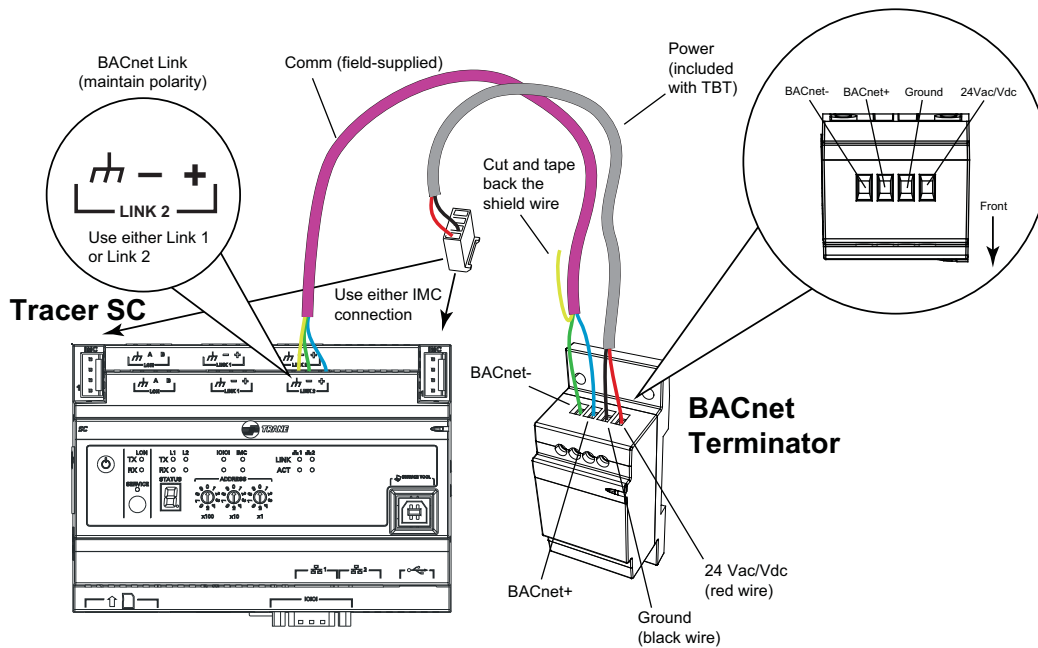

Medium Enclosure (optional)

The medium enclosure for Tracer DIN-mounted controllers is available in the following:

- 120 VAC (order number: X13651559010)
- 230 VAC (order number: X13651560010)

See Figure 19, p. 31 for dimensions.

Figure 19. Medium enclosure (dimensions)

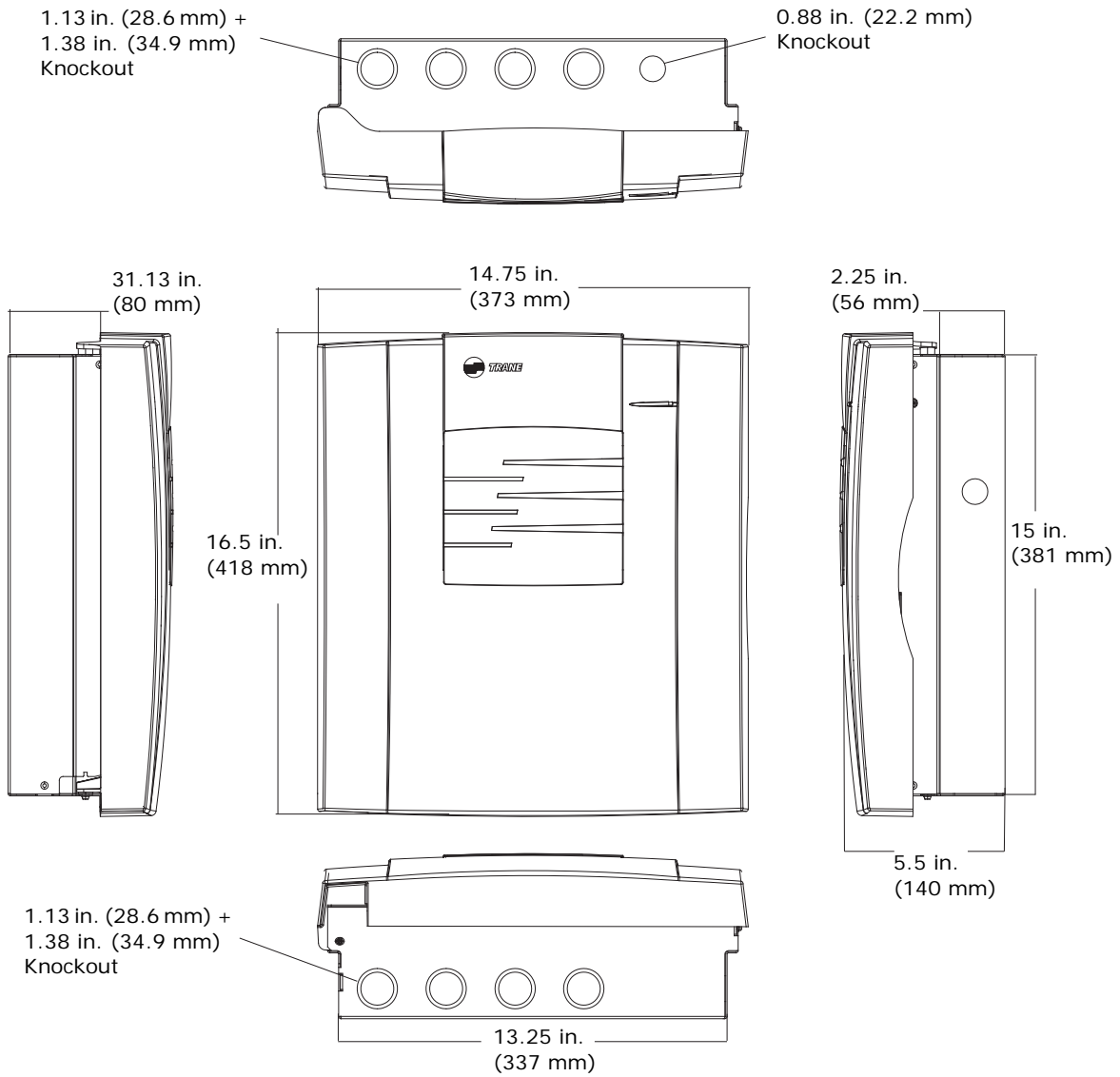

Large Enclosure (optional)

The large enclosure for Tracer DIN-mounted controllers is available in the following:

- 120 VAC
 - solid door (order number: X1365155201)
 - display-capable door (order number: X1365155301)
- 230 VAC Dual Transformer
 - solid door (order number: X1365155401)
 - display-capable door (order number: X1365155501)

Figure 20. Large enclosure (dimensions)

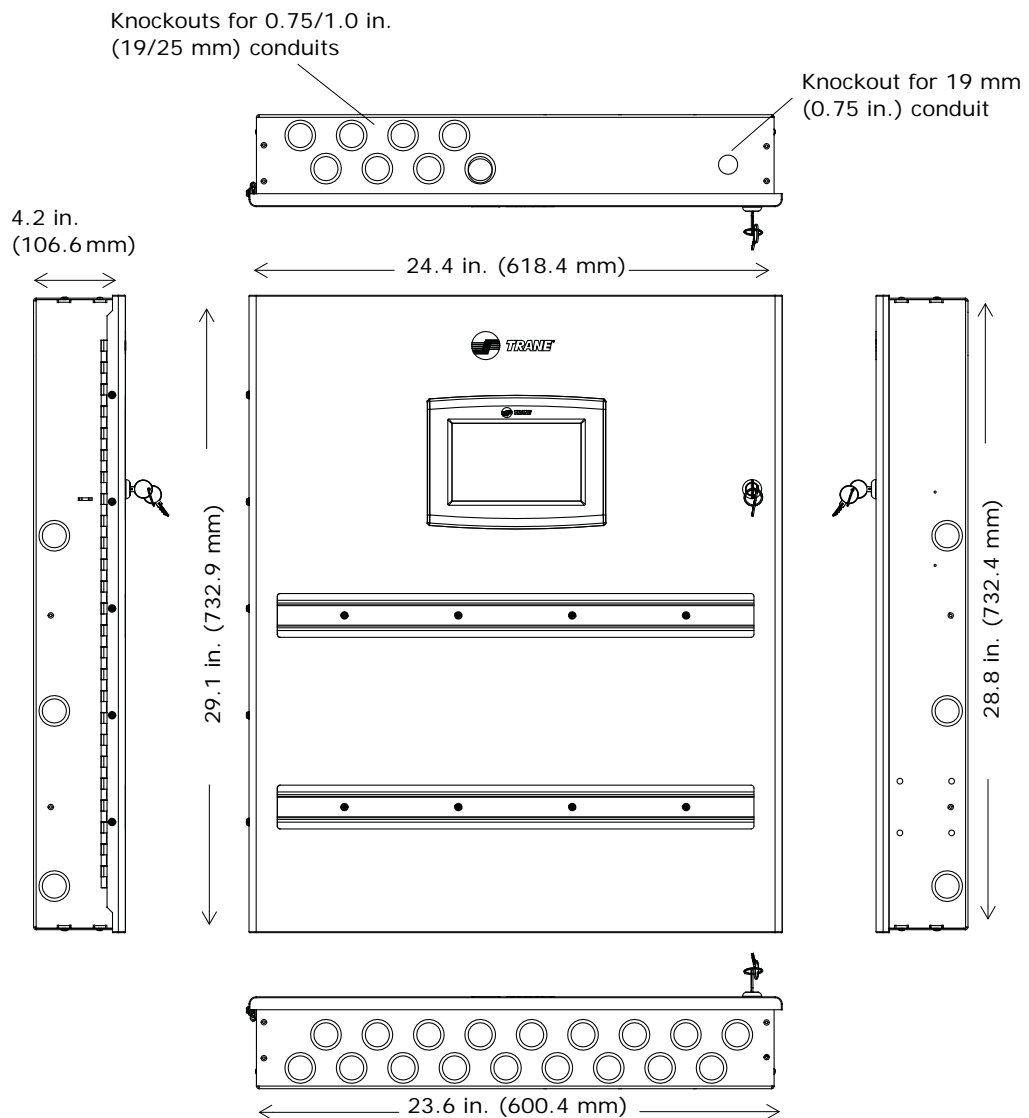



Trane optimizes the performance of homes and buildings around the world. A business of Ingersoll Rand, the leader in creating and sustaining safe, comfortable and energy efficient environments, Trane offers a broad portfolio of advanced controls and HVAC systems, comprehensive building services, and parts. For more information, visit www.Trane.com.

Trane has a policy of continuous product and product data improvement and reserves the right to change design and specifications without notice.

© 2015 Trane All rights reserved
BAS-PRC031N-EN 04 May 2015
Supersedes BAS-PRC031M-EN (28 Feb 2015)

We are committed to using environmentally
conscious print practices that reduce waste.

