

Table of Contents

Introduction	2
Electron Theory	4
Conductors, Insulators and Semiconductors	5
Electric Charges.....	7
Current.....	9
Voltage.....	11
Resistance	13
Simple Electric Circuit.....	15
Ohm's Law	16
DC Series Circuit	18
DC Parallel Circuit	23
Series-Parallel Circuits	30
Power.....	34
Magnetism	37
Electromagnetism	39
Introduction to AC.....	42
AC Generators	44
Frequency	47
Voltage and Current	48
Inductance	51
Capacitance	56
Inductive and Capacitive Reactance	61
Series R-L-C Circuit	67
Parallel R-L-C Circuit	69
Power and Power Factor in an AC Circuit.....	71
Transformers.....	75
Three-Phase Transformers	80
Review Answers.....	83
Final Exam	84
quickSTEP Online Courses	88

Introduction

Welcome to the first course in the STEP series, **Siemens Technical Education Program** designed to prepare our distributors to sell Siemens Energy & Automation products more effectively. This course covers Basics of Electricity and is designed to prepare you for subsequent courses on Siemens Energy & Automation products.

Upon completion of Basics of Electricity you will be able to:

- Explain the difference between conductors and insulators
- Use Ohm's Law to calculate current, voltage, and resistance
- Calculate equivalent resistance for series, parallel, or series-parallel circuits
- Calculate voltage drop across a resistor
- Calculate power given other basic values
- Identify factors that determine the strength and polarity of a current-carrying coil's magnetic field
- Determine peak, instantaneous, and effective values of an AC sine wave
- Identify factors that effect inductive reactance and capacitive reactance in an AC circuit
- Calculate total impedance of an AC circuit
- Explain the difference between real power and apparent power in an AC circuit
- Calculate primary and secondary voltages of single-phase and three-phase transformers
- Calculate kVA of a transformer

The objectives listed above may sound strange to you. You may also wonder why you would need to know these things to sell Siemens Energy & Automation products. Developing a basic knowledge of electrical concepts, however, will help you to better understand customer applications. In addition, you will be better able to describe products to customers and determine important differences between products.

If you are an employee of a Siemens Energy & Automation authorized distributor, fill out the final exam tear-out card and mail in the card. We will mail you a certificate of completion if you score a passing grade. Good luck with your efforts.

Electron Theory

Elements of an Atom

All matter is composed of molecules which are made up of a combination of **atoms**. Atoms have a nucleus with electrons orbiting around it. The nucleus is composed of protons and neutrons (not shown). Most atoms have an equal number of electrons and protons. **Electrons** have a negative charge (-). **Protons** have a positive charge (+). **Neutrons** are neutral. The negative charge of the electrons is balanced by the positive charge of the protons. Electrons are bound in their orbit by the attraction of the protons. These are referred to as bound electrons.

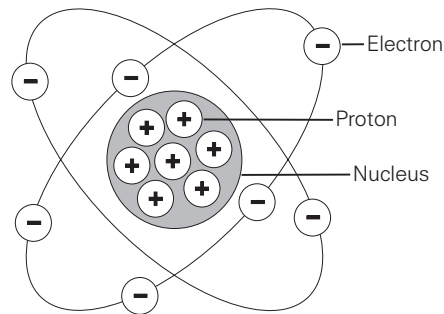

Free Electrons

Electrons in the outer band can become free of their orbit by the application of some external force such as movement through a magnetic field, friction, or chemical action. These are referred to as **free electrons**. A free electron leaves a void which can be filled by an electron forced out of orbit from another atom. As free electrons move from one atom to the next an electron flow is produced. This is the basis of electricity.

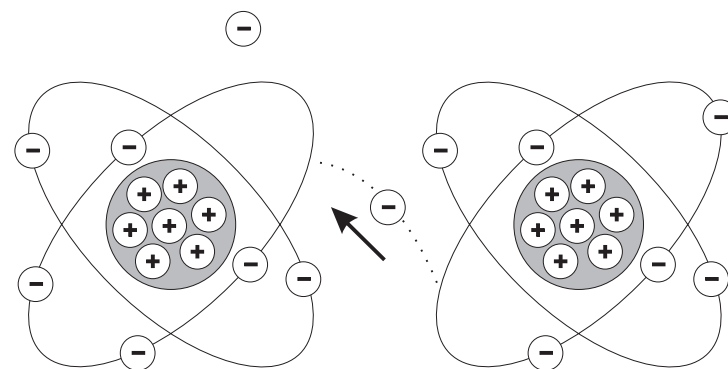

Conductors, Insulators and Semiconductors

Conductors

An **electric current** is produced when free electrons move from one atom to the next. Materials that permit many electrons to move freely are called conductors. Copper, silver, aluminum, zinc, brass, and iron are considered good **conductors**. Copper is the most common material used for conductors and is relatively inexpensive.

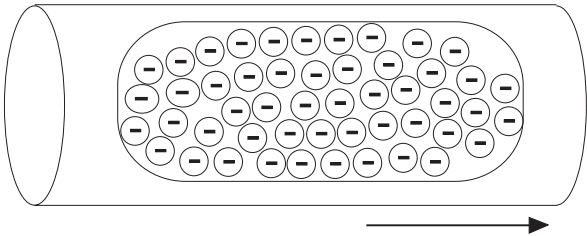

Insulators

Materials that allow few free electrons are called **insulators**. Materials such as plastic, rubber, glass, mica, and ceramic are good insulators.

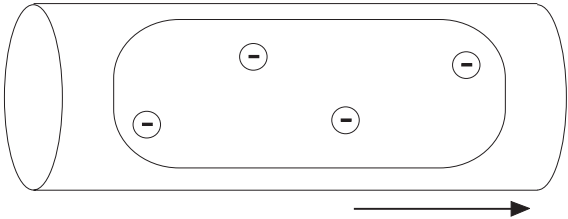

An electric cable is one example of how conductors and insulators are used. Electrons flow along a copper conductor to provide energy to an electric device such as a radio, lamp, or a motor. An insulator around the outside of the copper conductor is provided to keep electrons in the conductor.



Semiconductors

Semiconductor materials, such as silicon, can be used to manufacture devices that have characteristics of both conductors and insulators. Many semiconductor devices will act like a conductor when an external force is applied in one direction. When the external force is applied in the opposite direction, the semiconductor device will act like an insulator. This principle is the basis for transistors, diodes, and other solid-state electronic devices.

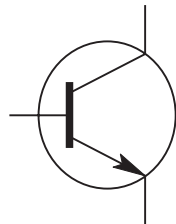

Transistor



Diode

Review 1

1. List the three basic elements of an atom and state the charge of each (positive, negative, or neutral).

Element	Charge
_____	_____
_____	_____
_____	_____

2. An electron forced out of orbit by an external force is called a _____ .
3. Conductors allow _____ free electrons to flow when an external electric force is applied.
4. Which of the following materials are good conductors?
 - a. copper
 - b. plastic
 - c. silver
 - d. rubber
 - e. aluminum
 - f. glass
 - g. iron
 - h. mica
5. Semiconductor devices can be manufactured to allow _____ electrons to flow in one direction and _____ electrons to flow in the opposite direction.

Electric Charges

Neutral State of an Atom

Elements are often identified by the number of electrons in orbit around the nucleus of the atoms making up the element and by the number of protons in the nucleus. A hydrogen atom, for example, has only one electron and one proton. An aluminum atom (illustrated) has 13 electrons and 13 protons. An atom with an equal number of electrons and protons is said to be electrically neutral.

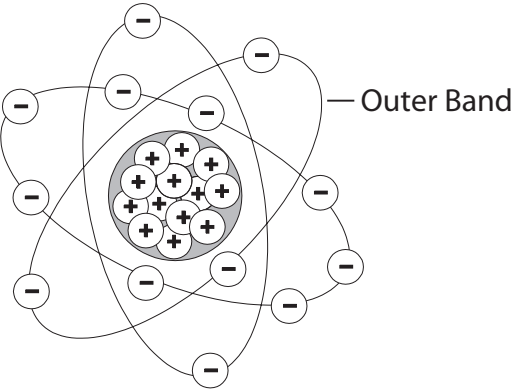

Positive and Negative Charges

Electrons in the outer band of an atom are easily displaced by the application of some external force. Electrons which are forced out of their orbits can result in a lack of electrons where they leave and an excess of electrons where they come to rest. The lack of electrons is called a **positive charge** because there are more protons than electrons. The excess of electrons has a **negative charge**. A positive or negative charge is caused by an absence or excess of electrons. The number of protons remains constant.

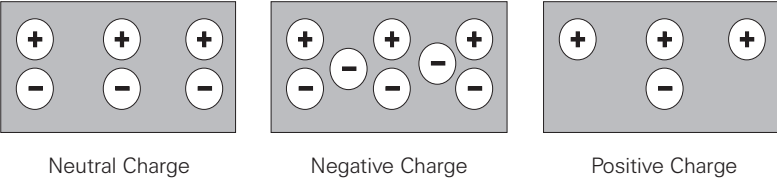

Attraction and Repulsion of Electric Charges

The old saying, "opposites attract," is true when dealing with electric charges. Charged bodies have an invisible electric field around them. When two like-charged bodies are brought together, their electric fields repel one body from the other. When two unlike-charged bodies are brought together, their electric fields attract one body to the other.

The electric field around a charged body forms invisible lines of force. These invisible lines of force cause the attraction or repulsion. Lines of force are shown leaving a body with a positive charge and entering a body with a negative charge.

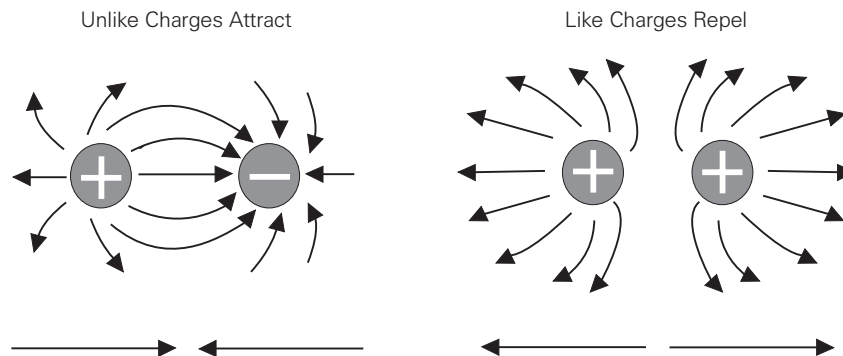

Coulomb's Law

During the 18th century a French scientist, Charles A. Coulomb, studied fields of force that surround charged bodies. Coulomb discovered that charged bodies attract or repel each other with a force that is directly proportional to the product of the charges, and inversely proportional to the square of the distance between them. Today we call this **Coulomb's Law of Charges**. Simply put, the force of attraction or repulsion depends on the strength of the charges and the distance between them.

Current

Electricity is the flow of free electrons in a conductor from one atom to the next atom in the same general direction. This flow of electrons is referred to as current and is designated by the symbol "I." Electrons move through a conductor at different rates and electric current has different values. Current is determined by the number of electrons that pass through a cross-section of a conductor in one second. We must remember that atoms are very small. It takes about 1,000,000,000,000,000,000,000,000 atoms to fill one cubic centimeter of a copper conductor. This number can be simplified using mathematical exponents. Instead of writing 24 zeros after the number 1, write 10^{24} . Trying to measure even small values of current would result in unimaginably large numbers. For this reason current is measured in **amperes** which is abbreviated "amps." The letter "A" is the symbol for amps. A current of one amp means that in one second about 6.24×10^{18} electrons move through a cross-section of conductor. These numbers are given for information only and you do not need to be concerned with them. It is important, however, to understand the concept of current flow.

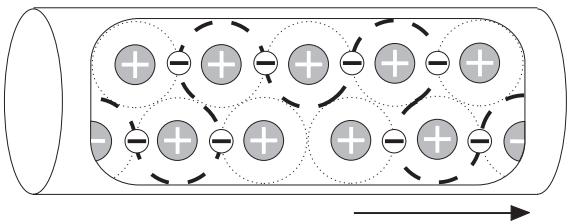

Units of Measurement

The following chart reflects special prefixes that are used when dealing with very small or large values of current:

Prefix	Symbol	Decimal
1 kiloampere	1 kA	1000 A
1 milliampere	1 mA	1/1000 A
1 microampere	1 μ A	1/1,000,000 A

Direction of Current Flow

Some authorities distinguish between electron flow and current flow. Conventional current flow theory ignores the flow of electrons and states that current flows from positive to negative. To avoid confusion, this book will use the **electron flow** concept which states that electrons flow from negative to positive.

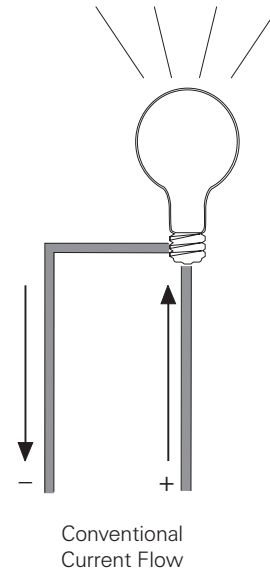
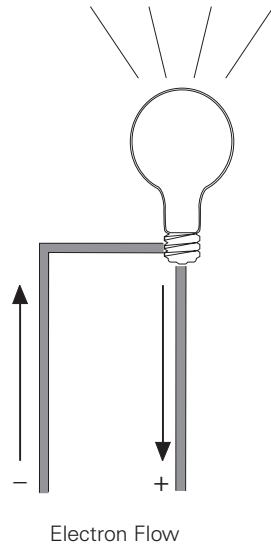

Voltage

Electricity can be compared with water flowing through a pipe. A force is required to get water to flow through a pipe. This force comes from either a water pump or gravity. **Voltage** is the force that is applied to a conductor that causes electric current to flow.

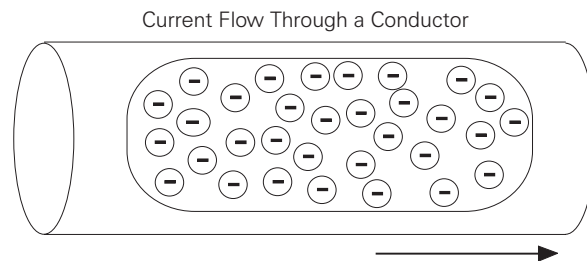
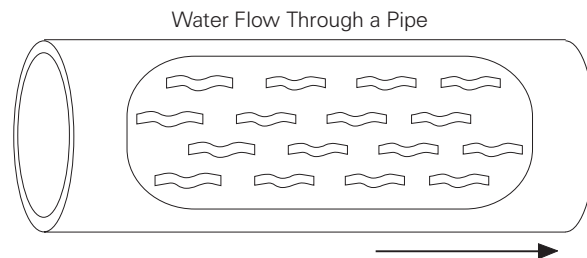

Electrons are negative and are attracted by positive charges. They will always be attracted from a source having an excess of electrons, thus having a negative charge, to a source having a deficiency of electrons, giving it a positive charge. The force required to make electricity flow through a conductor is called a difference in potential, electromotive force (emf), or voltage. Voltage is designated by the letter "E," or the letter "V." The unit of measurement for voltage is **volts** which is also designated by the letter "V."

Voltage Sources

An electrical voltage can be generated in various ways. A battery uses an electrochemical process. A car's alternator and a power plant generator utilize a magnetic induction process. All **voltage sources** share the characteristic of an excess of electrons at one terminal and a shortage at the other terminal. This results in a difference of potential between the two terminals.

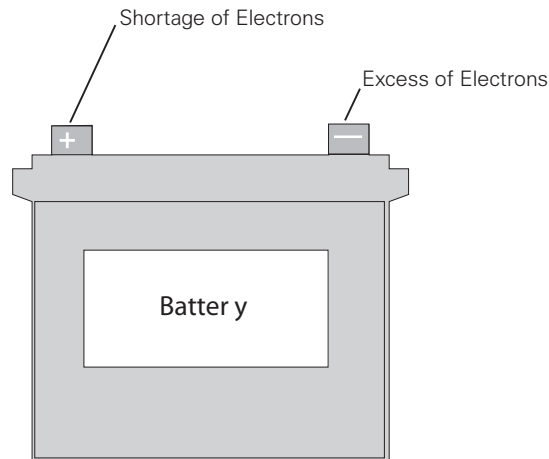

Voltage Circuit Symbol

The terminals of a battery are indicated symbolically on an electrical drawing by two lines. The longer line indicates the positive terminal. The shorter line indicates the negative terminal.

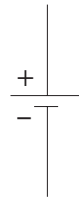

Units of Measurement

The following chart reflects special prefixes that are used when dealing with very small or large values of voltage:

Prefix	Symbol	Decimal
1 kilovolt	1 kV	1000 V
1 millivolt	1 mV	1/1000 V
1 microvolt	1 μ V	1/1,000,000 V

Resistance

A third factor that plays a role in an electrical circuit is **resistance**. All material impedes the flow of electrical current to some extent. The amount of resistance depends upon composition, length, cross-section and temperature of the resistive material. As a rule of thumb, resistance of a conductor increases with an increase of length or a decrease of cross-section. Resistance is designated by the symbol "R." The unit of measurement for resistance is **ohms** (Ω).

Resistance Circuit Symbols

Resistance is usually indicated symbolically on an electrical drawing by one of two ways. An unfilled rectangle is commonly used. A zigzag line may also be used.

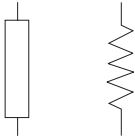

Resistance can be in the form of various components. A resistor may be placed in the circuit, or the circuit might contain other devices that have resistance.

Units of Measurement

The following chart reflects special prefixes that are commonly used when dealing with values of resistance:

Prefix	Symbol	Decimal
1 kilohm	1 k Ω	1000 Ω
1 megohm	1 M Ω	1,000,000 Ω

Review 2

1. Elements are identified by the number of _____ in orbit around the nucleus.
2. A material that has an excess of electrons is said to have a _____ charge.
3. A material that has a deficiency of electrons is said to have a _____ charge.
4. Like charges _____ and unlike charges _____ .
5. The force that is applied to a conductor to cause current flow is _____ .
6. Electrons move from _____ .
 - a. positive to negative
 - b. negative to positive
7. With an increase of length or a decrease of cross-section of a conductor, resistance will _____ .
 - a. increase
 - b. decrease

Simple Electric Circuit

An Electric Circuit

A fundamental relationship exists between current, voltage, and resistance. A simple **electric circuit** consists of a voltage source, some type of load, and a conductor to allow electrons to flow between the voltage source and the load. In the following circuit a battery provides the voltage source, electrical wire is used for the conductor, and a light provides the resistance. An additional component has been added to this circuit, a switch. There must be a complete path for current to flow. If the switch is open, the path is incomplete and the light will not illuminate. Closing the switch completes the path, allowing electrons to leave the negative terminal and flow through the light to the positive terminal.

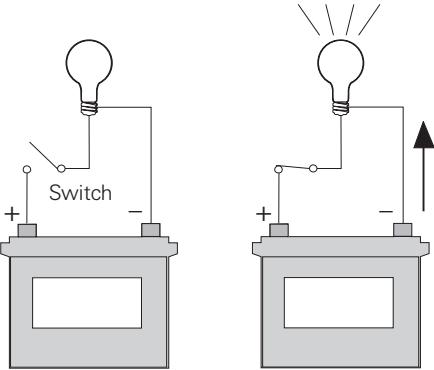

An Electrical Circuit Schematic

The following **schematic** is a representation of an electrical circuit, consisting of a battery, a resistor, a voltmeter and an ammeter. The ammeter, connected in series with the circuit, will show how much current flows in the circuit. The voltmeter, connected across the voltage source, will show the value of voltage supplied from the battery. Before an analysis can be made of a circuit, we need to understand Ohm's Law.

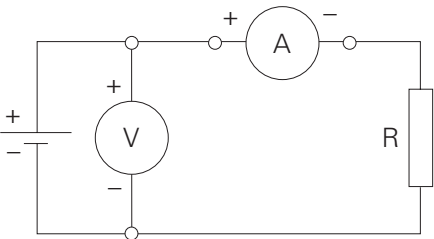

Ohm's Law

George Simon Ohm and Ohm's Law

The relationship between current, voltage and resistance was studied by the 19th century German mathematician, George Simon Ohm. Ohm formulated a law which states that current varies directly with voltage and inversely with resistance. From this law the following formula is derived:

$$I = \frac{E}{R} \quad \text{or} \quad \text{Current} = \frac{\text{Voltage}}{\text{Resistance}}$$

Ohm's Law is the basic formula used in all electrical circuits. Electrical designers must decide how much voltage is needed for a given load, such as computers, clocks, lamps and motors. Decisions must be made concerning the relationship of current, voltage and resistance. All electrical design and analysis begins with Ohm's Law. There are three mathematical ways to express Ohm's Law. Which of the formulas is used depends on what facts are known before starting and what facts need to be known.

$$I = \frac{E}{R} \quad E = I \times R \quad R = \frac{E}{I}$$

Ohm's Law Triangle

There is an easy way to remember which formula to use. By arranging current, voltage and resistance in a triangle, one can quickly determine the correct formula.

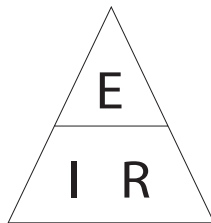

Using the Triangle

To use the triangle, cover the value you want to calculate. The remaining letters make up the formula.

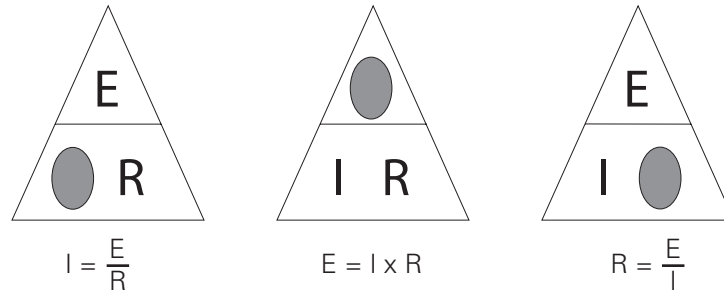

Ohm's Law can only give the correct answer when the correct values are used. Remember the following three rules:

- Current is always expressed in amperes or amps
- Voltage is always expressed in volts
- Resistance is always expressed in ohms

Examples of Solving Ohm's Law

Using the simple circuit below, assume that the voltage supplied by the battery is 10 volts, and the resistance is 5 Ω .

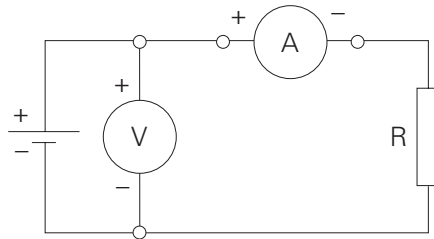

To find how much current is flowing through the circuit, cover the "I" in the triangle and use the resulting equation.

$$I = \frac{E}{R} \rightarrow I = \frac{10 \text{ Volts}}{5 \Omega} \rightarrow I = 2 \text{ Amps}$$

Using the same circuit, assume the ammeter reads 200 mA and the resistance is known to be 10 Ω . To solve for voltage, cover the "E" in the triangle and use the resulting equation.

$$E = I \times R \rightarrow E = 0.2 \times 10 \rightarrow E = 2 \text{ Volts}$$

Remember to use the correct decimal equivalent when dealing with numbers that are preceded with milli (m), micro (μ) or kilo (k). In this example, had 200 been used instead of converting the value to 0.2, the wrong answer of 2000 volts would have been calculated.

DC Series Circuit

Resistance in a Series Circuit

A **series circuit** is formed when any number of resistors are connected end-to-end so that there is only one path for current to flow. The resistors can be actual resistors or other devices that have resistance. The following illustration shows four resistors connected end-to-end. There is one path of current flow from the negative terminal of the battery through R4, R3, R2, R1 returning to the positive terminal.

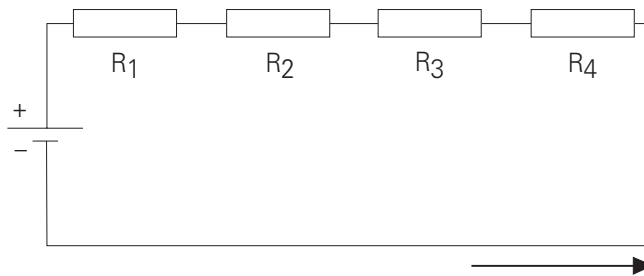

Formula for Series Resistance

The values of resistance add in a series circuit. If a 4 Ω resistor is placed in series with a 6 Ω resistor, the total value will be 10 Ω . This is true when other types of resistive devices are placed in series. The mathematical formula for resistance in series is:

$$R_t = R_1 + R_2 + R_3 + R_4 + R_5 \dots + R_n$$

In this example, the circuit includes five series resistors.

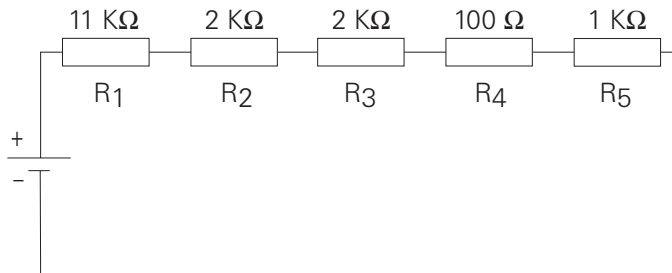

$$\begin{aligned} R_t &= R_1 + R_2 + R_3 + R_4 + R_5 \\ R_t &= 11,000 + 2,000 + 2,000 + 100 + 1,000 \\ R_t &= 16,100 \Omega \end{aligned}$$

Current in a Series Circuit

The equation for total resistance in a series circuit allows us to simplify a circuit. Using Ohm's Law, the value of current can be calculated. Current is the same anywhere it is measured in a series circuit.

$$I = \frac{E}{R}$$

$$I = \frac{12}{10}$$

$$I = 1.2 \text{ Amps}$$

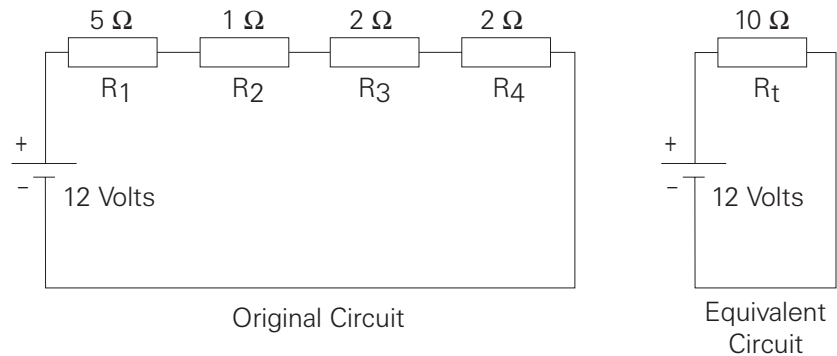

Voltage in a Series Circuit

Voltage can be measured across each of the resistors in a circuit. The voltage across a resistor is referred to as a voltage drop. A German physicist, **Gustav Kirchhoff**, formulated a law which states *the sum of the voltage drops across the resistances of a closed circuit equals the total voltage applied to the circuit*. In the following illustration, four equal value resistors of 1.5 Ω each have been placed in series with a 12 volt battery. Ohm's Law can be applied to show that each resistor will "drop" an equal amount of voltage.

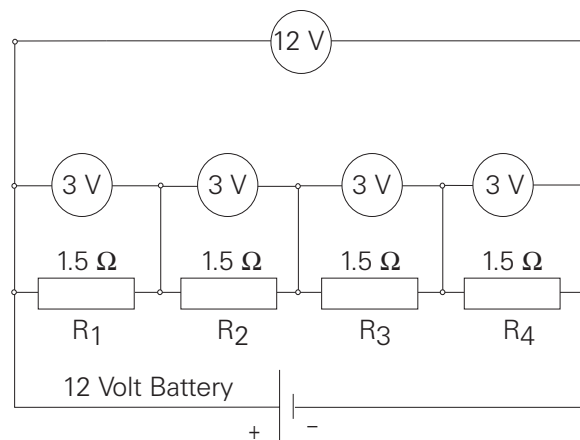

First, solve for total resistance:

$$\begin{aligned}R_t &= R_1 + R_2 + R_3 + R_4 \\R_t &= 1.5 + 1.5 + 1.5 + 1.5 \\R_t &= 6 \Omega\end{aligned}$$

Second, solve for current:

$$\begin{aligned}I &= \frac{E}{R} \\I &= \frac{12}{6} \\I &= 2 \text{ Amps}\end{aligned}$$

Third, solve for voltage across any resistor:

$$\begin{aligned}E &= I \times R \\E &= 2 \times 1.5 \\E &= 3 \text{ Volts}\end{aligned}$$

If voltage were measured across any single resistor, the meter would read three volts. If voltage were read across a combination of R_3 and R_4 the meter would read six volts. If voltage were read across a combination of R_2 , R_3 , and R_4 the meter would read nine volts. If the voltage drops of all four resistors were added together the sum would be 12 volts, the original supply voltage of the battery.

Voltage Division in a Series Circuit

It is often desirable to use a voltage potential that is lower than the supply voltage. To do this, a voltage divider, similar to the one illustrated, can be used. The battery represents E_{in} which in this case is 50 volts. The desired voltage is represented by E_{out} , which mathematically works out to be 40 volts. To calculate this voltage, first solve for total resistance.

$$\begin{aligned}R_t &= R_1 + R_2 \\R_t &= 5 + 20 \\R_t &= 25 \Omega\end{aligned}$$

Second, solve for current:

$$I = \frac{E_{in}}{R_t}$$

$$I = \frac{50}{25}$$

$$I = 2 \text{ Amps}$$

Finally, solve for voltage:

$$E_{out} = I \times R_2$$

$$E_{out} = 2 \times 20$$

$$E_{out} = 40 \text{ Volts}$$

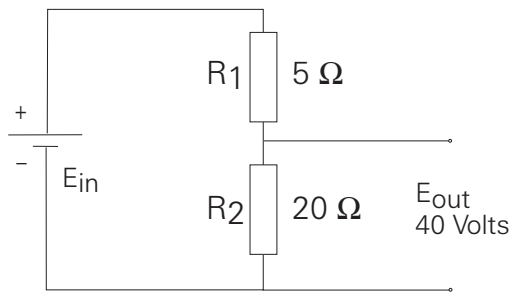

Review 3

1. The basic Ohm's Law formula is _____ .
2. When solving circuit problems; current must always be expressed in _____ , voltage must always be expressed in _____ , and resistance must always be expressed in _____ .
3. The total current of a simple circuit with a voltage supply of 12 volts and a resistance of 24Ω is _____ amps.
4. What is the total resistance of a series circuit with the following values: $R_1=10 \Omega$, $R_2=15 \Omega$, and $R_3=20 \Omega$? _____ Ω .
5. What is total current of a series circuit that has a 120 volt supply and 60Ω resistance?
6. In the following circuit, the voltage dropped across R_1 is _____ volts and R_2 is _____ volts.

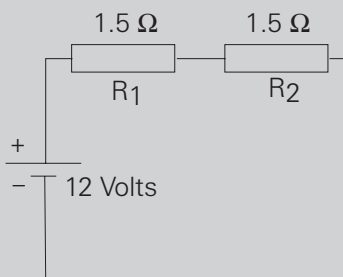

7. In the following circuit, voltage dropped across R_1 is _____ volts and across R_2 is _____ volts.

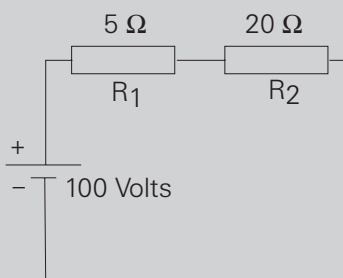

DC Parallel Circuit

Resistance in a Parallel Circuit

A **parallel circuit** is formed when two or more resistances are placed in a circuit side-by-side so that current can flow through more than one path. The illustration shows two resistors placed side-by-side. There are two paths of current flow. One path is from the negative terminal of the battery through R_1 returning to the positive terminal. The second path is from the negative terminal of the battery through R_2 returning to the positive terminal of the battery.

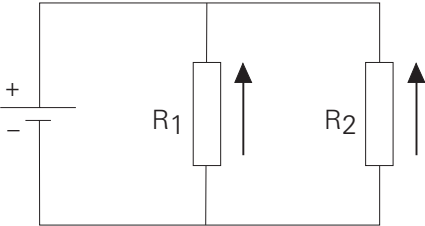

Formula for Equal Value Resistors in a Parallel Circuit

To determine the total resistance when resistors are of equal value in a parallel circuit, use the following formula:

$$R_t = \frac{\text{Value of any one Resistor}}{\text{Number of Resistors}}$$

In the following illustration there are three 15Ω resistors. The total resistance is:

$$R_t = \frac{\text{Value of any one Resistor}}{\text{Number of Resistor}}$$

$$R_t = \frac{15}{3}$$

$$R_t = 5 \Omega$$

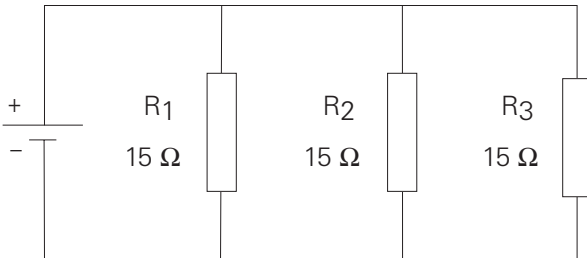

Formula for Unequal Resistors in a Parallel Circuit

There are two formulas to determine total resistance for resistors of any value in a parallel circuit. The first formula is used when there are any number of resistors.

$$\frac{1}{R_t} = \frac{1}{R_1} + \frac{1}{R_2} + \frac{1}{R_3} \dots + \frac{1}{R_n}$$

In the following illustration, there are three resistors, each of different value. Solve for the total resistance as follows:

$$\frac{1}{R_t} = \frac{1}{R_1} + \frac{1}{R_2} + \frac{1}{R_3}$$

$$\frac{1}{R_t} = \frac{1}{5} + \frac{1}{10} + \frac{1}{20} \quad \text{Insert Values for the Resistors}$$

$$\frac{1}{R_t} = \frac{4}{20} + \frac{2}{20} + \frac{1}{20} \quad \text{Find the Lowest Common Denominator}$$

$$\frac{1}{R_t} = \frac{7}{20} \quad \text{Add the Numerators}$$

$$\frac{R_t}{1} = \frac{20}{7} \quad \text{Invert Both Sides of the Equation}$$

$$R_t = 2.86 \, \Omega \quad \text{Divide}$$

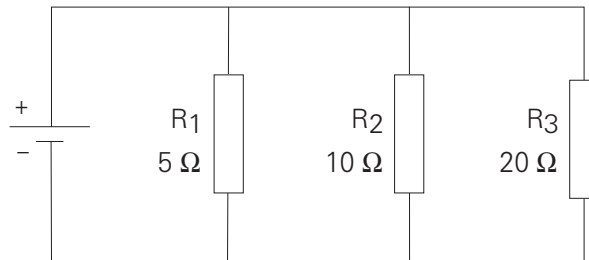

The second formula is used when there are only two resistors.

$$R_t = \frac{R_1 \times R_2}{R_1 + R_2}$$

In the following illustration there are two resistors, each of different value. The total resistance is:

$$R_t = \frac{R_1 \times R_2}{R_1 + R_2}$$

$$R_t = \frac{5 \times 10}{5 + 10}$$

$$R_t = \frac{50}{15}$$

$$R_t = 3.33 \Omega$$

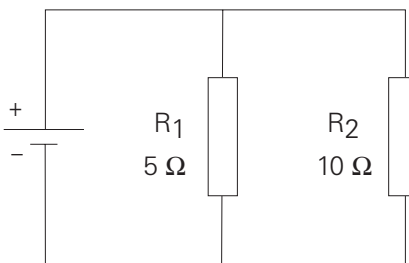

Voltage in a Parallel Circuit

When resistors are placed in parallel across a voltage source, the voltage is the same across each resistor. In the following illustration three resistors are placed in parallel across a 12 volt battery. Each resistor has 12 volts available to it.

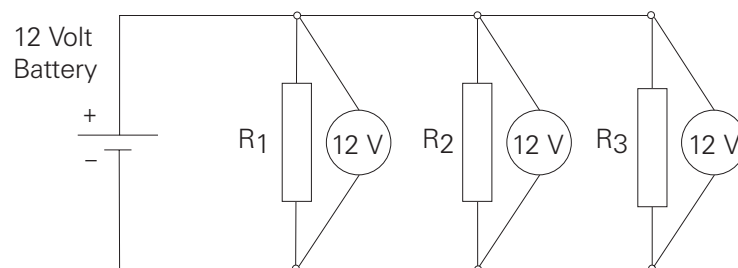

Current in a Parallel Circuit

Current flowing through a parallel circuit divides and flows through each branch of the circuit.

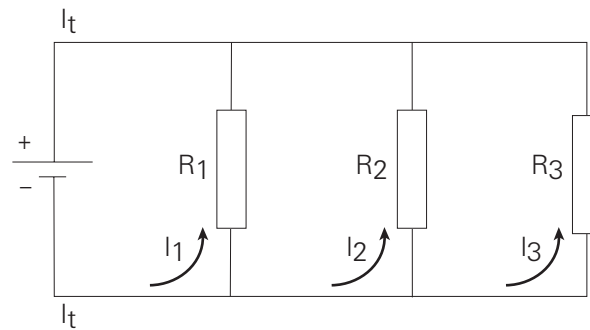

Total current in a parallel circuit is equal to the sum of the current in each branch. The following formula applies to current in a parallel circuit.

$$I_t = I_1 + I_2 + I_3 \dots + I_n$$

Current Flow with Equal Value Resistors in a Parallel Circuit

When equal resistances are placed in a parallel circuit, opposition to current flow is the same in each branch. In the following circuit R_1 and R_2 are of equal value. If total current (I_t) is 10 amps, then 5 amps would flow through R_1 and 5 amps would flow through R_2 .

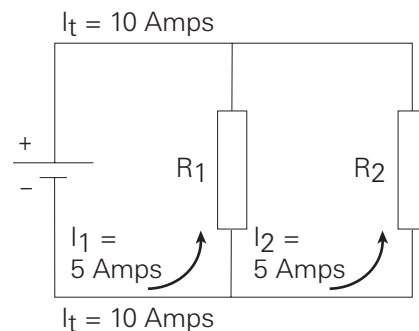

$$I_t = I_1 + I_2$$
$$I_t = 5 \text{ Amps} + 5 \text{ Amps}$$
$$I_t = 10 \text{ Amps}$$

Current Flow with Unequal Value Resistors in a Parallel Circuit

When unequal value resistors are placed in a parallel circuit, opposition to current flow is not the same in every circuit branch. Current is greater through the path of least resistance. In the following circuit R_1 is $40\ \Omega$ and R_2 is $20\ \Omega$. Small values of resistance means less opposition to current flow. More current will flow through R_2 than R_1 .

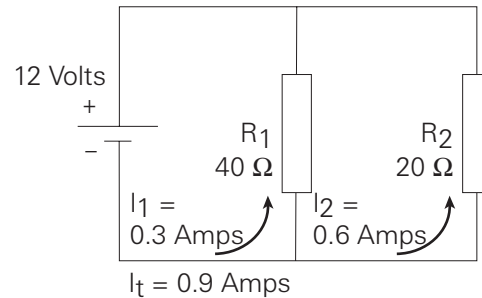

Using Ohm's Law, the total current for each circuit can be calculated.

$$I_1 = \frac{E}{R_1}$$

$$I_1 = \frac{12\ \text{Volts}}{40\ \Omega}$$

$$I_1 = 0.3\ \text{Amps}$$

$$I_2 = \frac{E}{R_2}$$

$$I_2 = \frac{12\ \text{Volts}}{20\ \Omega}$$

$$I_2 = 0.6\ \text{Amps}$$

$$I_t = I_1 + I_2$$

$$I_t = 0.3\ \text{Amps} + 0.6\ \text{Amps}$$

$$I_t = 0.9\ \text{Amps}$$

Total current can also be calculated by first calculating total resistance, then applying the formula for Ohm's Law.

$$R_t = \frac{R_1 \times R_2}{R_1 + R_2}$$

$$R_t = \frac{40 \Omega \times 20 \Omega}{40 \Omega + 20 \Omega}$$

$$R_t = \frac{800 \Omega}{60 \Omega}$$

$$R_t = 13.333 \Omega$$

$$I_t = \frac{E}{R_t}$$

$$I_t = \frac{12 \text{ Volts}}{13.333 \Omega}$$

$$I_t = 0.9 \text{ Amps}$$

Review 4

1. The total resistance of a parallel circuit that has four $20\ \Omega$ resistors is _____ Ω .

2. R_t for the following circuit is _____ Ω .

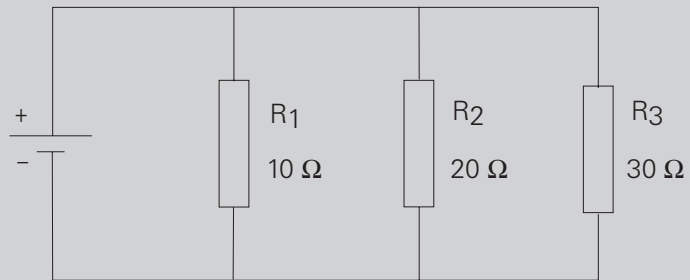

3. R_t for the following circuit is _____ Ω .

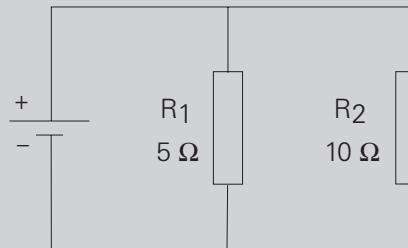

4. Voltage available at R_2 in the following circuit is _____ volts.

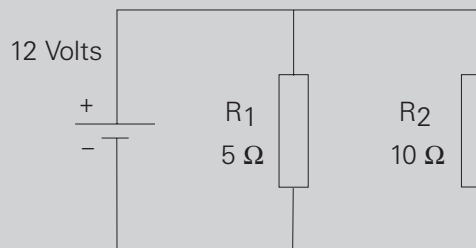

5. In a parallel circuit with two resistors of equal value and a total current flow of 12 amps, the value of current through each resistor is _____ amps.

6. In the following circuit, current flow through R_1 is _____ amps, and through R_2 is _____ amps.

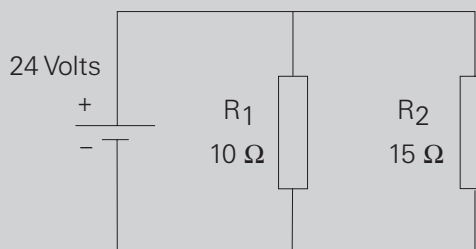

Series-Parallel Circuits

Series-parallel circuits are also known as compound circuits. At least three resistors are required to form a series-parallel circuit. The following illustrations show the two simplest ways a series-parallel combination can be represented.

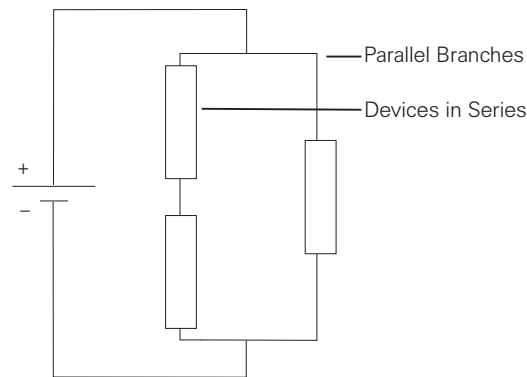
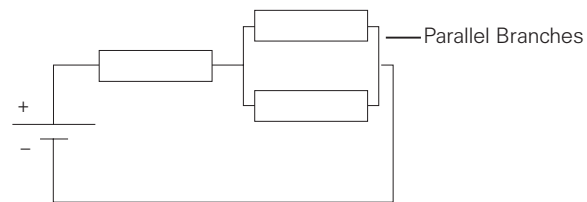

Simplifying a Series-Parallel The formulas required for solving current, voltage and resistance problems have already been defined. To solve a series-parallel circuit, reduce the compound circuits to equivalent simple circuits. In the following illustration, R_1 and R_2 are parallel with each other. R_3 is in series with the parallel circuit of R_1 and R_2 .

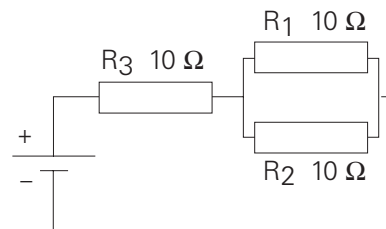

First, use the formula to determine total resistance of a parallel circuit to find the total resistance of R_1 and R_2 . When the resistors in a parallel circuit are equal, the following formula is used:

$$R = \frac{\text{Value of any One Resistor}}{\text{Number of Resistors}}$$

$$R = \frac{10 \Omega}{2}$$

$$R = 5 \Omega$$

Second, redraw the circuit showing the equivalent values. The result is a simple series circuit which uses already learned equations and methods of problem solving.

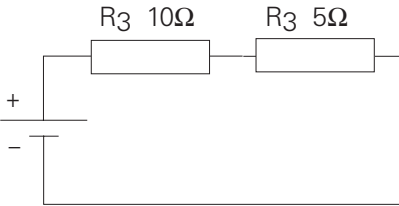

Simplifying a Series-Parallel Circuit to a Parallel Circuit

In the following illustration R_1 and R_2 are in series with each other. R_3 is in parallel with the series circuit of R_1 and R_2 .

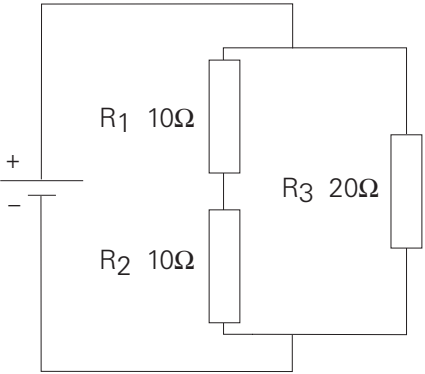

First, use the formula to determine total resistance of a series circuit to find the total resistance of R_1 and R_2 . The following formula is used:

$$R = R_1 + R_2$$

$$R = 10 \Omega + 10 \Omega$$

$$R = 20 \Omega$$

Second, redraw the circuit showing the equivalent values. The result is a simple parallel circuit which uses already learned equations and methods of problem solving.

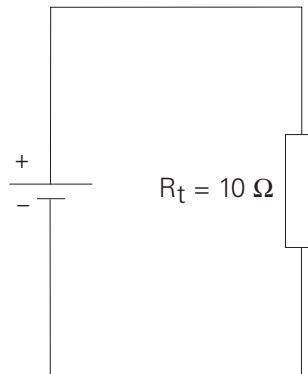
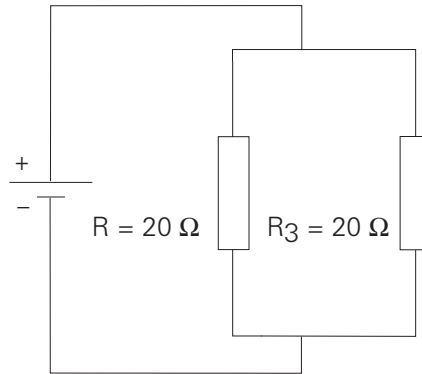

Review 5

1. Calculate equivalent resistance for R_1 and R_2 and total resistance for the entire circuit.

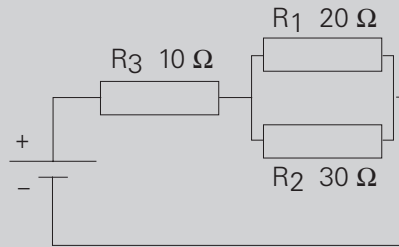

R_1, R_2 equivalent resistance = _____ Ω

Total resistance = _____ Ω

2. Calculate equivalent resistance for R_1 and R_2 and total resistance for the entire circuit.

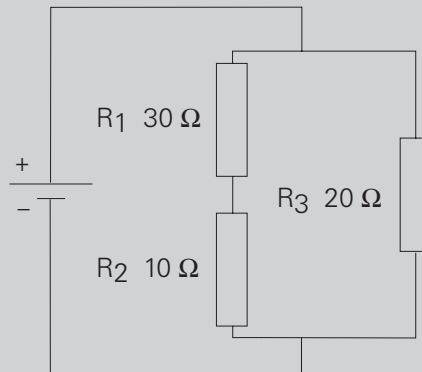

R_1, R_2 equivalent resistance = _____ Ω

Total resistance = _____ Ω

Power

Work

Whenever a force of any kind causes motion, **work** is accomplished. In the illustration below work is done when a mechanical force is used to lift a weight. If a force were exerted without causing motion, then no work is done.

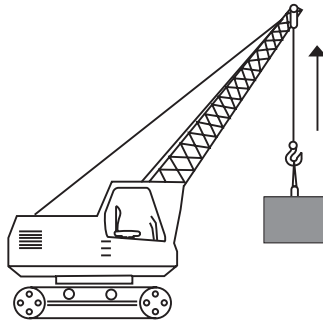

Electric Power

In an electrical circuit, voltage applied to a conductor will cause electrons to flow. Voltage is the force and electron flow is the motion. The rate at which work is done is called **power** and is represented by the symbol "P." Power is measured in **watts**, represented by the symbol "W." In a direct current circuit, one watt is *the rate work is done in a circuit when 1 amp flows with 1 volt applied.*

Power Formulas

In a DC circuit, power is the product of voltage times current. Later in this course, you will learn a slightly different version of this relationship for an alternating current (AC) circuit.

$$P = E \times I$$

or

$$P = EI$$

Two other power equations can be derived from this formula by substituting other components of Ohm's Law.

$$P = I^2R$$

and

$$P = \frac{E^2}{R}$$

DC Circuit Example

In the following illustration, power can be calculated using any of the power formulas.

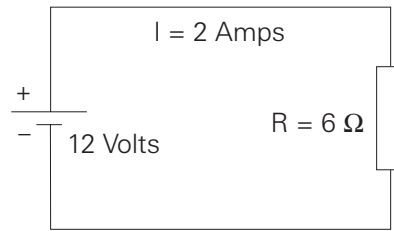

$$\begin{aligned}P &= EI \\P &= 12 \text{ Volts} \times 2 \text{ Amps} \\P &= 24 \text{ Watts}\end{aligned}$$

$$\begin{aligned}P &= I^2R \\P &= (2 \text{ Amps})^2 \times 6 \Omega \\P &= 24 \text{ Watts}\end{aligned}$$

$$P = \frac{E^2}{R}$$

$$P = \frac{(12 \text{ Volts})^2}{6 \Omega}$$

$$P = \frac{144}{6}$$

$$P = 24 \text{ Watts}$$

Additional Calculations

Electrical equipment often has a power rating expressed in watts. This rating is an indication of the rate at which electrical equipment converts electrical energy into some other form of energy, such as heat or mechanical energy. If the power associated with a device and its operating voltage are known, other quantities can be easily calculated. For example, a common household lamp may be rated for 120 volts and 100 watts. Using Ohm's Law, the rated value of resistance of the lamp can be calculated.

$$P = \frac{E^2}{R} \text{ which can be transposed to } R = \frac{E^2}{P}$$

$$R = \frac{(120 \text{ Volts})^2}{100 \text{ Watts}}$$

$$R = 144 \Omega$$

Using the basic Ohm's Law formula, the amount of current flow for the 120 volt, 100 watt lamp can be calculated.

$$I = \frac{E}{R}$$

$$I = \frac{120 \text{ Volts}}{144 \Omega}$$

$$I = 0.833 \text{ Amps}$$

By comparison, a lamp rated for 120 volts and 75 watts has a resistance of 192Ω and a current of 0.625 amps would flow if the lamp had the rated voltage applied to it.

$$R = \frac{E^2}{P}$$

$$R = \frac{(120 \text{ Volts})^2}{75 \text{ Watts}}$$

$$R = 192 \Omega$$

$$I = \frac{E}{R}$$

$$I = \frac{120 \text{ Volts}}{192 \Omega}$$

$$I = 0.625 \text{ Amps}$$

Magnetism

The principles of **magnetism** are an integral part of electricity. In fact, magnetism can be used to produce electric current and vice versa.

Types of Magnets

When we think of a permanent magnet, we often envision a horse-shoe or bar magnet or a compass needle, but permanent magnets come in many shapes.

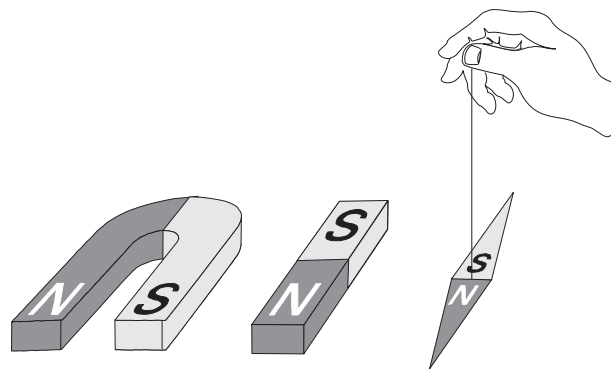

However, all magnets have two characteristics. They attract iron and, if free to move (like the compass needle), a magnet will assume a north-south orientation.

Magnetic Lines of Flux

Every magnet has two **poles**, one north pole and one south pole. Invisible **magnetic lines of flux** leave the north pole and enter the south pole. While the lines of flux are invisible, the effects of magnetic fields can be made visible. When a sheet of paper is placed on a magnet and iron filings loosely scattered over it, the filings will arrange themselves along the invisible lines of flux.

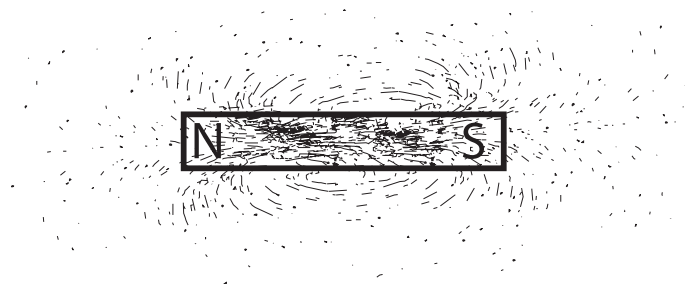

By drawing lines the way the iron filings have arranged themselves, the following picture is obtained. Broken lines indicate the paths of magnetic flux lines. The field lines exist outside and inside the magnet. The magnetic lines of flux always form closed loops. Magnetic lines of flux leave the north pole and enter the south pole, returning to the north pole through the magnet.

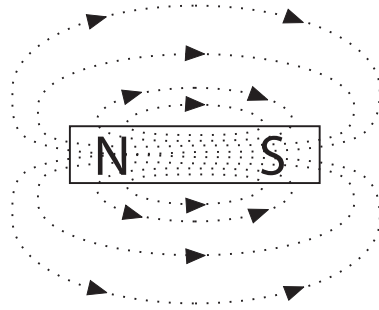

Interaction between Two Magnets

When two magnets are brought together, the magnetic flux field around the magnets causes some form of interaction. Two unlike poles brought together cause the magnets to attract each other. Two like poles brought together cause the magnets to repel each other.

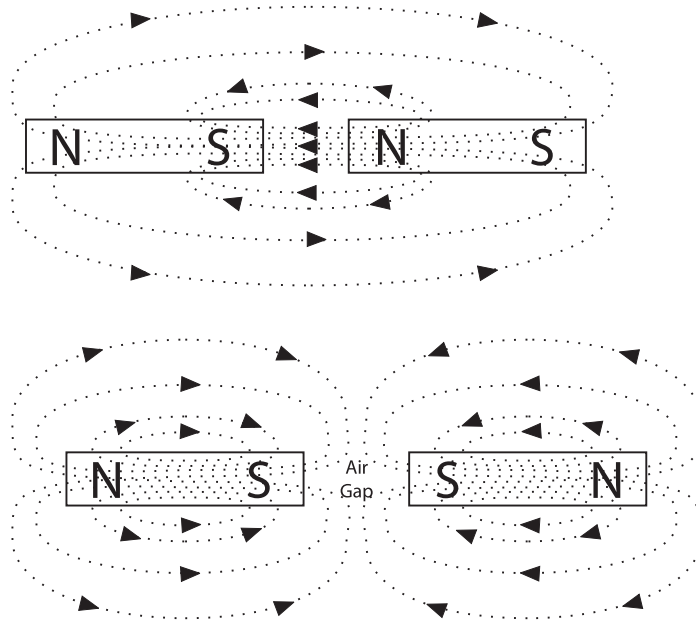

Electromagnetism

Left-Hand Rule for Conductors

An electromagnetic field is a magnetic field generated by current flow in a conductor. Every electric current generates a magnetic field and a relationship exists between the direction of current flow and the direction of the magnetic field. The **left-hand rule for conductors** demonstrates this relationship. If a current-carrying conductor is grasped with the left hand with the thumb pointing in the direction of electron flow, the fingers will point in the direction of the magnetic lines of flux.

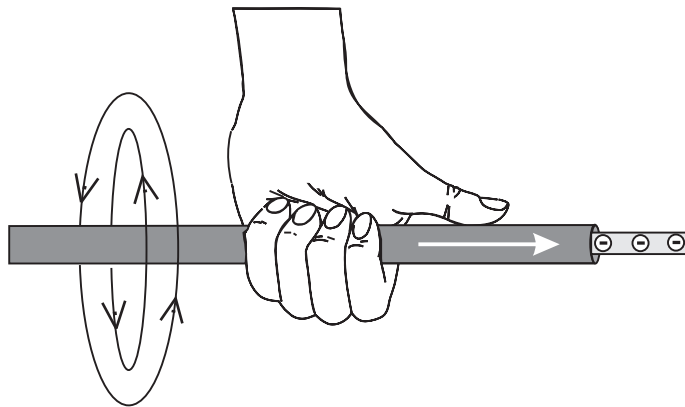

Current-Carrying Coil

A coil of wire carrying a current, acts like a magnet. Individual loops of wire act as small magnets. The individual fields add together to form one magnet. The strength of the field can be increased by adding more turns to the coil, increasing the amount of current, or winding the coil around a material such as iron that conducts magnetic flux more easily than air.

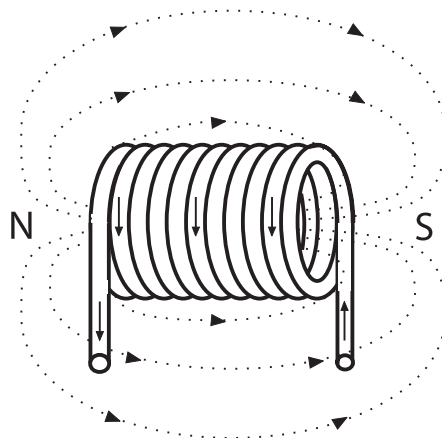

Left-Hand Rule for Coils

A **left-hand rule exists for coils** to determine the direction of the magnetic field. The fingers of the left hand are wrapped around the coil in the direction of electron flow. The thumb points to the north pole of the coil.

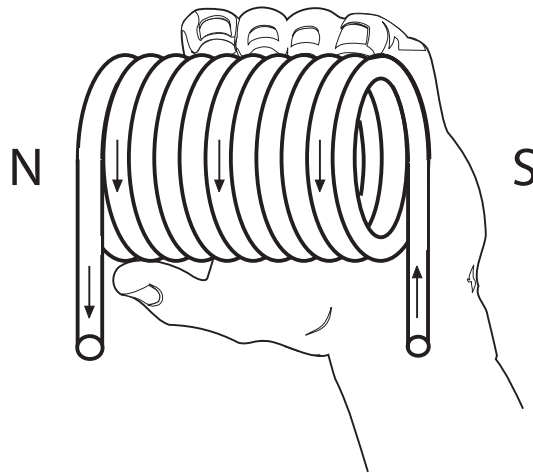

Electromagnets

An **electromagnet** is composed of a coil of wire wound around a core. The core is made of soft iron or some other material that easily conducts magnetic lines of force. When current is passed through the coil, the core becomes magnetized. The ability to control the strength and direction of the magnetic force makes electromagnets useful. As with permanent magnets, opposite poles attract. An electromagnet can be made to control the strength of its field which controls the strength of the magnetic poles.

A large variety of electrical devices such as motors, circuit breakers, contactors, relays and motor starters use electromagnetic principles.

Review 6

1. The rate at which work is done is called _____ .
2. The basic formulas for power in a DC circuit are:
 $P = I \times \underline{\quad}$, $P = I^2 \times \underline{\quad}$, and $P = \frac{\underline{\quad}}{R}$
3. In a circuit with a 12 volt supply and 4 Ω resistance, the power consumed is _____ watts.
4. The two characteristics of all magnets are: they attract and hold _____ , and, if free to move, they will assume roughly a _____ position.
5. Lines of flux always leave the _____ pole and enter the _____ pole.
6. The left-hand rule for conductors states that, when the _____ hand is placed on a current-carrying conductor with the _____ pointing in the direction of electron flow, the fingers will point in the direction of _____ .

Introduction to AC

The supply of current for electrical devices may come from a direct current (DC) source, or an **alternating current** (AC) source. In a direct current circuit, electrons flow continuously in one direction from the source of power through a conductor to a load and back to the source of power. Voltage in direct current remains constant. DC power sources include batteries and DC generators.

By contrast, an AC generator makes electrons flow first in one direction then in another. In fact, an AC generator reverses its terminal polarities many times a second, causing current to change direction with each reversal.

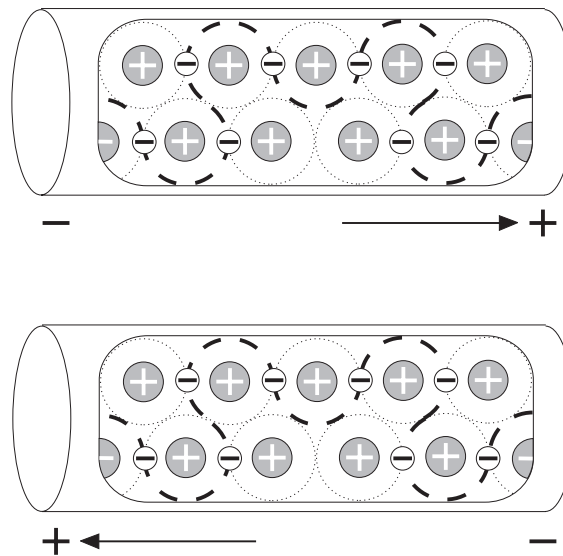

AC Sine Wave

Alternating voltage and current vary continuously. The graphic representation for AC is a **sine wave**. A sine wave can represent current or voltage. There are two axes. The vertical axis represents the direction and magnitude of current or voltage. The horizontal axis represents time.

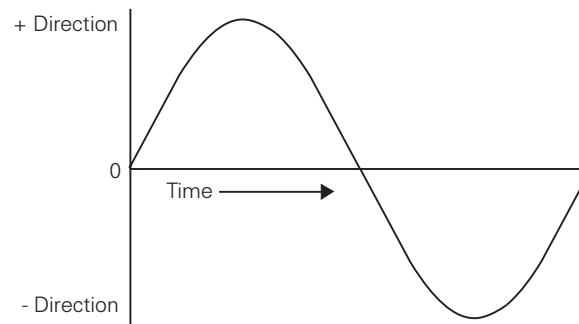

When the waveform is above the time axis, current is flowing in one direction. This is referred to as the positive direction. When the waveform is below the time axis, current is flowing in the opposite direction. This is referred to as the negative direction. A sine wave moves through a complete rotation of 360 degrees, which is referred to as one cycle. Alternating current goes through many of these cycles each second.

Single-Phase and Three-Phase AC Power

Alternating current is divided into **single-phase** and **three-phase** types. Single-phase power is used for small electrical demands such as found in the home. Three-phase power is used where large blocks of power are required, such as found in commercial applications and industrial plants. Single-phase power is shown in the above illustration. Three-phase power, as shown in the following illustration, is a continuous series of three overlapping AC cycles. Each wave represents a phase, and is offset by 120 electrical degrees.

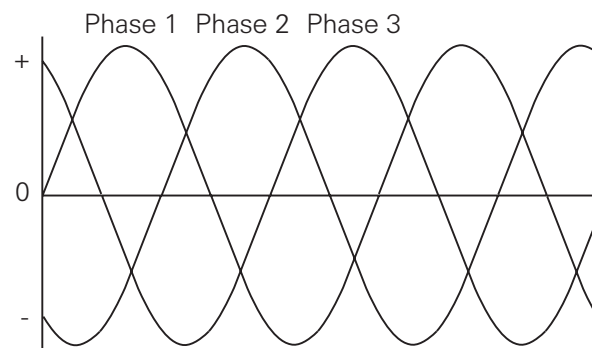

AC Generators

Basic Generator

A basic **generator** consists of a magnetic field, an armature, slip rings, brushes and a resistive load. In a commercial generator, the magnetic field is created by an electromagnet, but, for this simple generator, permanent magnets are used. An armature is any number of conductive wires wound in loops which rotates through the magnetic field. For simplicity, one loop is shown. When a conductor is moved through a magnetic field, a voltage is induced in the conductor. As the armature rotates through the magnetic field, a voltage is generated in the armature which causes current to flow. Slip rings are attached to the armature and rotate with it. Carbon brushes ride against the slip rings to conduct current from the armature to a resistive load.

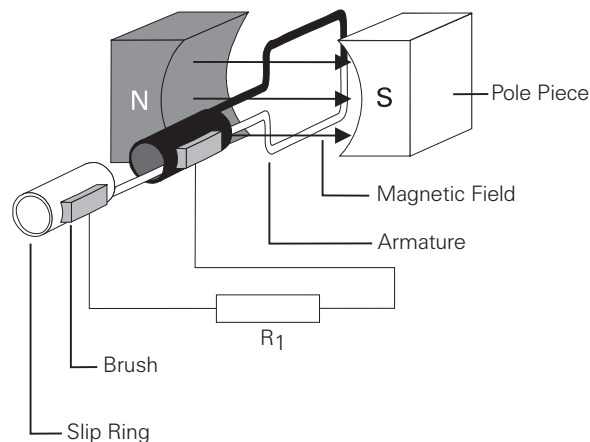

Basic Generator Operation

An armature rotates through the magnetic field. At an initial position of zero degrees, the armature conductors are moving parallel to the magnetic field and not cutting through any magnetic lines of flux. No voltage is induced.

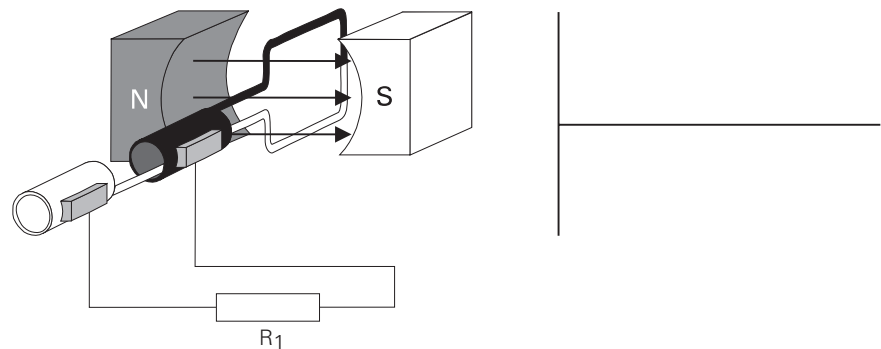

Generator Operation from Zero to 90 Degrees

As the armature rotates from zero to 90 degrees, the conductors cut through more and more lines of flux, building up to a maximum induced voltage in the positive direction.

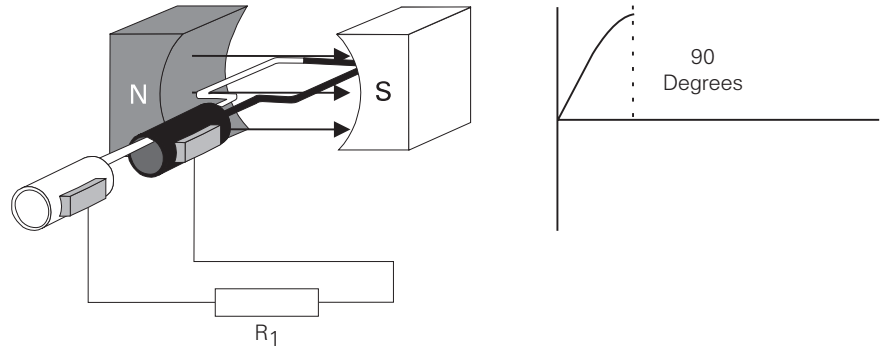

Generator Operation from 90 to 180 Degrees

The armature continues to rotate from 90 to 180 degrees, cutting fewer lines of flux. The induced voltage decreases from a maximum positive value to zero.

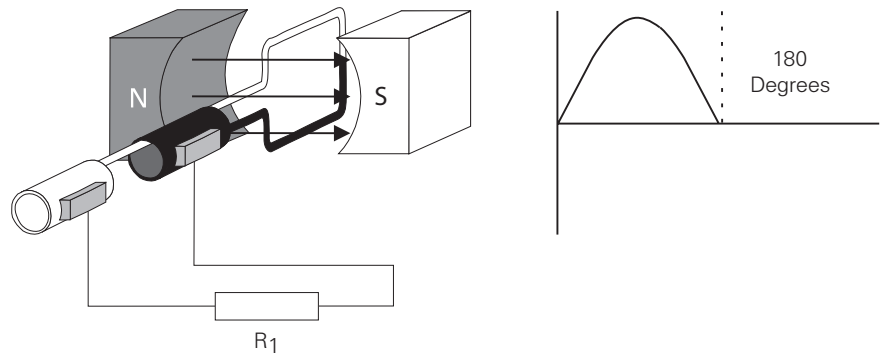

Generator Operation from 180 to 270 Degrees

As the armature continues to rotate from 180 degrees to 270 degrees, the conductors cut more lines of flux, but in the opposite direction, and voltage is induced in the negative direction, building up to a maximum at 270 degrees.

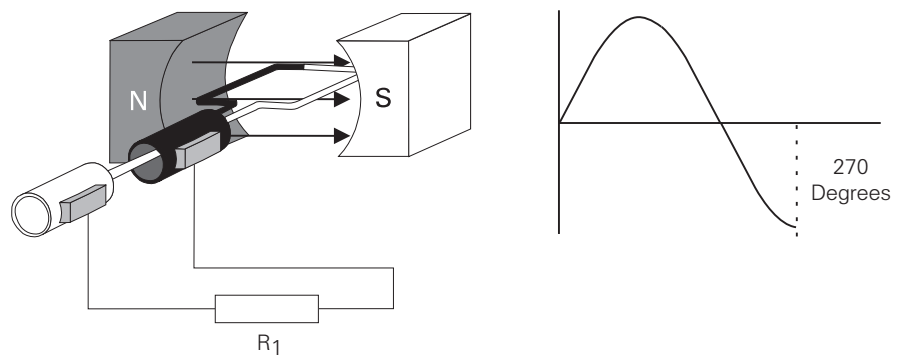

Generator Operation from 270 to 360 Degrees

As the armature continues to rotate from 270 to 360 degrees, induced voltage decreases from a maximum negative value to zero. This completes one cycle. The armature continues to rotate at a constant speed causing the cycle to repeat as long as the armature rotates.

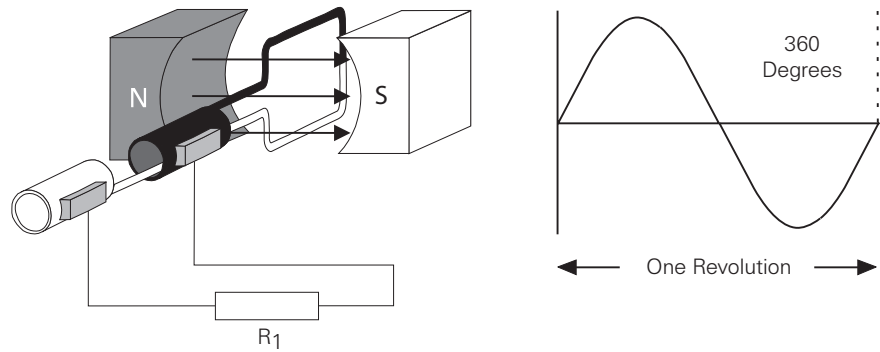

Frequency

The number of cycles per second of voltage induced in the armature is the **frequency** of the generator. If the armature rotates at a speed of 60 revolutions per second, the generated voltage will be 60 cycles per second. The recognized unit for frequency is **hertz**, abbreviated "Hz." 1 Hz is equal to 1 cycle per second. Power companies generate and distribute electricity at very low frequencies. The standard power line frequency in the United States and many other countries is 60 Hz. 50 Hz is also a common power line frequency used throughout the world. The following illustration shows 15 cycles in 1/4 second which is equivalent to 60 Hz.

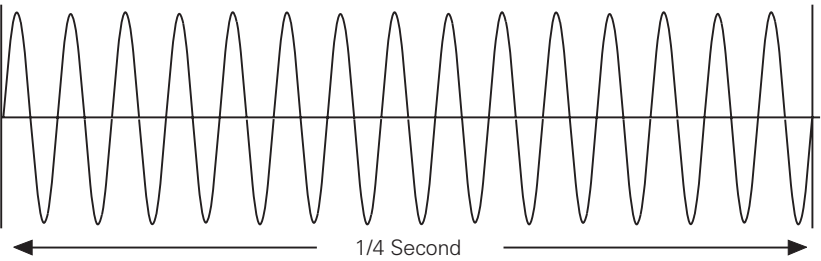

Four-Pole AC Generator

The frequency is the same as the number of rotations per second if the magnetic field is produced by only two poles. An increase in the number of poles, would cause an increase in the number of cycles completed in a revolution. A two-pole generator would complete one cycle per revolution and a four-pole generator would complete two cycles per revolution. An AC generator produces one cycle per revolution for each pair of poles.

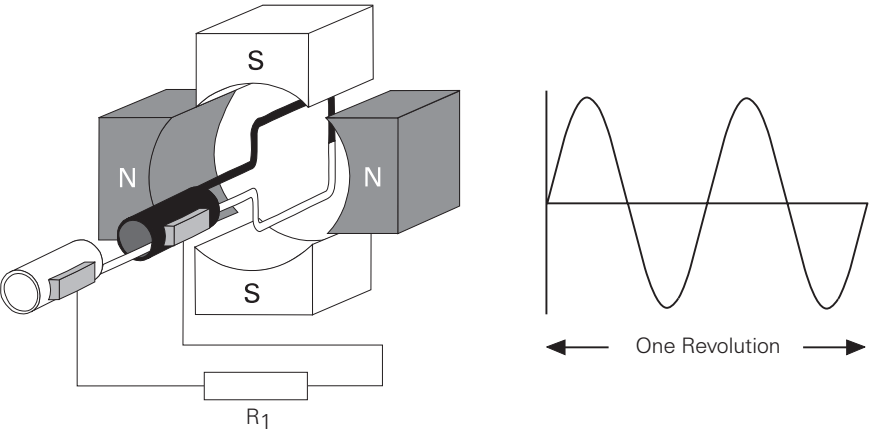

Voltage and Current

Peak Value

Voltage and current in an AC circuit rise and fall over time in a pattern referred to as a **sine wave**. The **peak value** of a sine wave occurs twice each cycle, once at the positive maximum value and once at the negative maximum value.

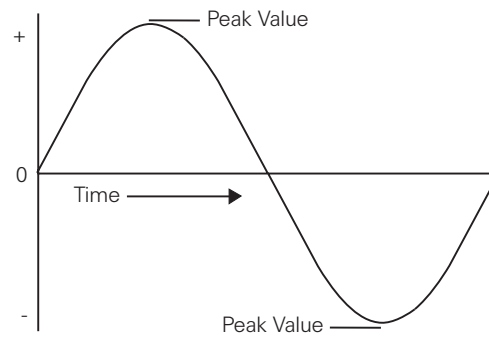

Peak-to-Peak Value

The value of the voltage or current between the peak positive and peak negative values is called the **peak-to-peak value**.

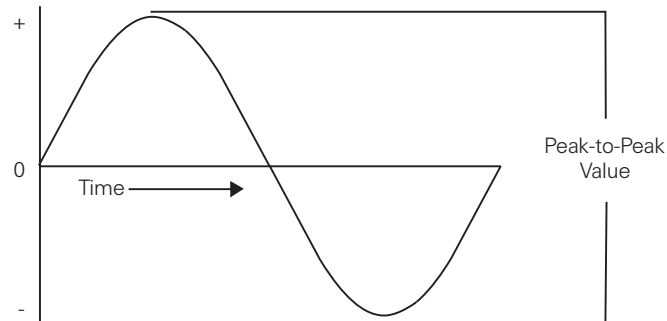

Instantaneous Value

The **instantaneous value** is the value at any one point in the sine wave.

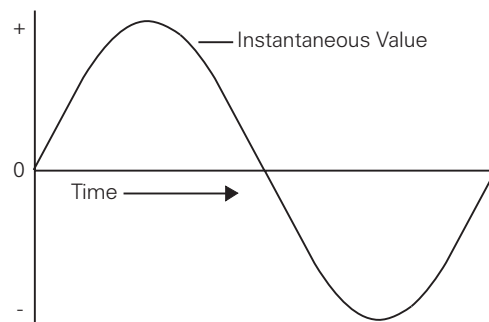

Calculating Instantaneous Voltage

The voltage waveform produced as the armature rotates through 360 degrees rotation is called a sine wave because the instantaneous voltage (e) is related to the sine trigonometric function. The sine of an angle is represented symbolically as $\sin \theta$, where the Greek letter theta (θ) represents the angle. The sine curve is a graph of the following equation for values of θ from 0 to 360 degrees:

$$e = E_{\text{peak}} \times \sin \theta$$

Instantaneous voltage is equal to the peak voltage times the sine of the angle of the generator armature. The sine value is obtained from trigonometric tables. The following table shows selected instantaneous values.

Angle	Sin θ	Angle	Sin θ
30 Degrees	0.5	210 Degrees	-0.5
60 Degrees	0.866	240 Degrees	-0.866
90 Degrees	1	270 Degrees	-1
120 Degrees	0.866	300 Degrees	-0.866
150 Degrees	0.5	330 Degrees	-0.5
180 Degrees	0	360 Degrees	0

The following example illustrates instantaneous values at 90, 150, and 240 degrees. The peak voltage is equal to 100 volts. By substituting the sine at the instantaneous angle value, the instantaneous voltage can be calculated.

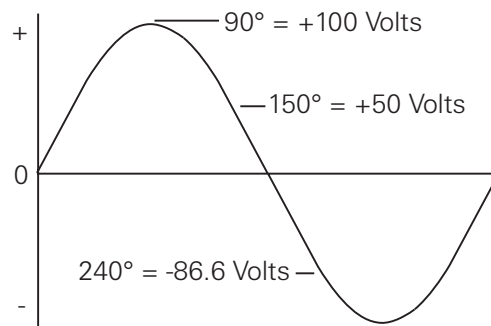

Any instantaneous value can be calculated. For example:

$$\begin{aligned} 240^\circ \\ e &= 100 \times -0.866 \\ e &= -86.6 \text{ volts} \end{aligned}$$

Effective Value of an AC Sine Wave

The instantaneous value of an alternating voltage and current are constantly changing values. However, there is a method for translating the varying values into an equivalent constant value, referred to as the **effective value** of voltage or current. This is also known as the **RMS value**. RMS is an abbreviation of the mathematical term root-mean-square. For example, a common voltage used in many applications is 120 volts, this is an RMS value, which is equal to the peak value times 0.707.

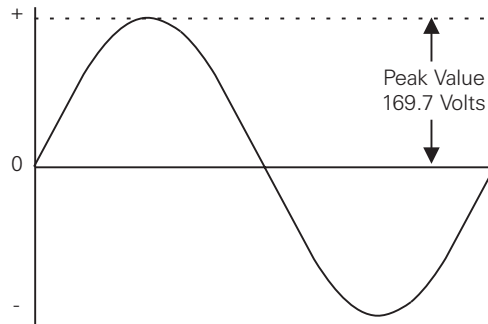

The effective value of AC is defined in terms of an equivalent heating effect when compared to DC. One RMS ampere of current flowing through a resistance will produce heat at the same rate as one DC ampere.

It is sometimes necessary to know the peak value of an AC voltage or current when the RMS value is known. To calculate the peak value, multiply the effective value by 1.41. For example, if the effective value is 100 volts, the peak value is 141 volts.

Review 7

1. A _____ is the graphic representation of AC voltage or current values over time.
2. Each phase of three phase AC power is offset by _____ degrees.
3. An AC generator produces _____ cycle(s) per revolution for each pair of poles.
4. What is the instantaneous voltage at 240 degrees for a sine wave with a peak voltage of 150 volts?
5. What is the effective voltage for a sine wave with a peak voltage of 150 volts?

Inductance

The circuits studied to this point have been resistive. Resistance and voltage are not the only circuit properties that effect current flow, however. **Inductance** is the property of an electric circuit that opposes any change in electric current. Resistance opposes current flow, inductance opposes change in current flow. Inductance is designated by the letter "L". The unit of measurement for inductance is the **henry** (h).

Current Flow and Field Strength

Current flow produces a magnetic field in a conductor. The amount of current determines the strength of the magnetic field. As current flow increases, field strength increases, and as current flow decreases, field strength decreases.

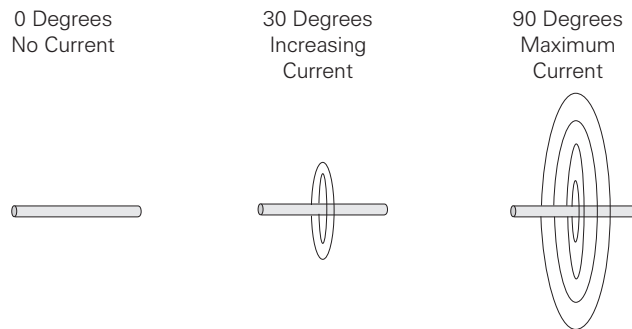

Any change in current causes a corresponding change in the magnetic field surrounding the conductor. Current is constant for a regulated DC source, except when the circuit is turned on and off, or when there is a load change. However, alternating current is constantly changing, and inductance is continually opposing the change. A change in the magnetic field surrounding the conductor induces a voltage in the conductor. This self-induced voltage opposes the change in current. This is known as counter emf. This opposition causes a delay in the time it takes current to attain its new steady value. If current increases, inductance tries to hold it down. If current decreases, inductance tries to hold it up. Inductance is somewhat like mechanical inertia which must be overcome to get a mechanical object moving or to stop a mechanical object from moving. A vehicle, for example, takes a few moments to accelerate to a desired speed, or decelerate to a stop.

Inductors

All conductors have inductance, but **inductors** are coils of wire wound for a specific inductance. For some applications, inductors are wound around a metal core to further concentrate the inductance. The inductance of a coil is determined by the number of turns in the coil, the coil diameter and length, and the core material. An inductor is usually indicated symbolically on an electrical drawing as a curled line or a filled rectangle.

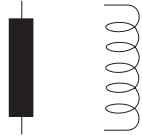

Simple Inductive Circuit

In a resistive circuit, current change is considered instantaneous. If an inductor is used, the current does not change as quickly.

For the purpose of explanation, a DC circuit is used here to describe the operation of an inductor. There will always be some amount of resistance and inductance in any circuit. The electrical wire used in the circuit has some resistance and inductance. In addition, inductors also have resistance. However, to simplify examples in this book, the resistance and inductance of the wiring and the resistance of inductors are not considered.

In the following circuit, initially the switch is in position 2, and there is no current flowing through the ammeter (A). When the switch is moved to position 1, current will rise rapidly at first, then more slowly as the maximum value is approached.

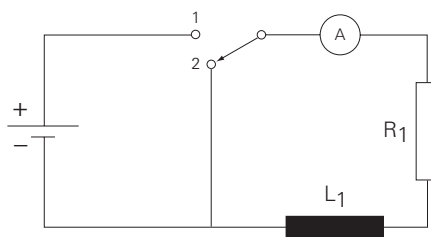

Inductive Time Constant

The time required for the current to rise to its maximum value is determined by the ratio of inductance (in henrys) to resistance (in ohms). This ratio is called the **time constant** of the inductive circuit. A time constant is the time (in seconds) required for the circuit current to rise to 63.2% of its maximum value. When the switch is closed in the previous circuit, current will begin to flow. During the first time constant current rises to 63.2% of its maximum value. During the second time constant, current rises to 63.2% of the remaining 36.8%, or a total of 86.4%. It takes about five time constants for current to reach its maximum value.

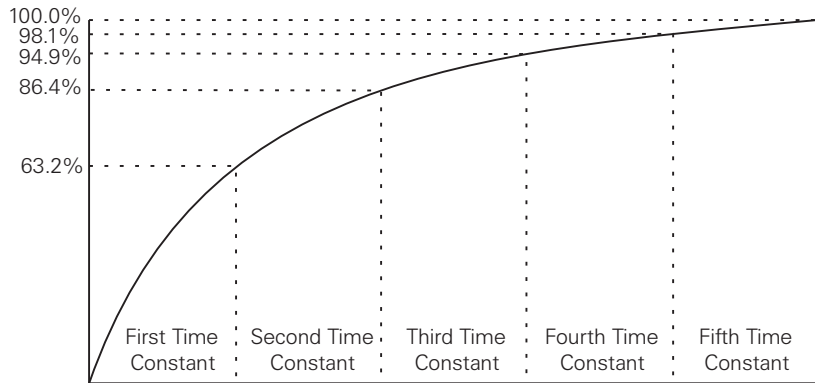

Similarly, when the switch in the previous circuit is returned to position 2, the magnetic field around the inductor will begin to collapse, returning stored energy to the circuit, and it will take about five time constants for current to reach zero.

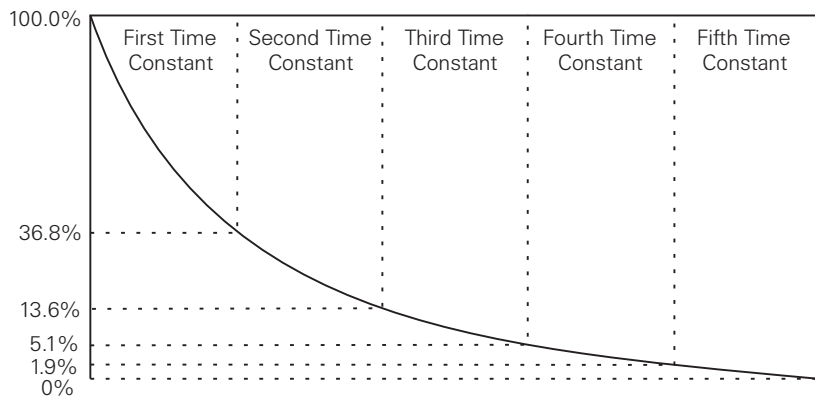

Calculating the Time Constant of an Inductive Circuit

The time constant is designated by the symbol “ τ ”. To determine the time constant of an inductive circuit use one of the following formulas:

$$\tau \text{ (in seconds)} = \frac{L \text{ (henrys)}}{R \text{ (ohms)}}$$

$$\tau \text{ (in milliseconds)} = \frac{L \text{ (millihenrys)}}{R \text{ (ohms)}}$$

$$\tau \text{ (in microseconds)} = \frac{L \text{ (microhenrys)}}{R \text{ (ohms)}}$$

In the following illustration, L_1 is equal to 15 millihenrys and R_1 is equal to 5Ω . When the switch is closed, it will take 3 milliseconds for current to rise from zero to 63.2% of its maximum value and approximately 15 milliseconds for full current to be reached.

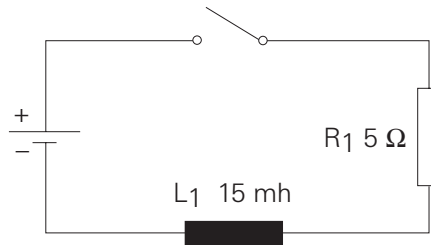

$$\tau = \frac{15 \text{ mh}}{5 \ \Omega}$$

$$\tau = 3 \text{ milliseconds}$$

Formula for Series Inductors

The same rules for calculating total resistance can be applied to calculating total inductance. In the following circuit, an AC generator is used to supply electrical power to four inductors. Total inductance of series inductors is calculated using the following formula:

$$L_t = L_1 + L_2 + L_3 \dots + L_n$$

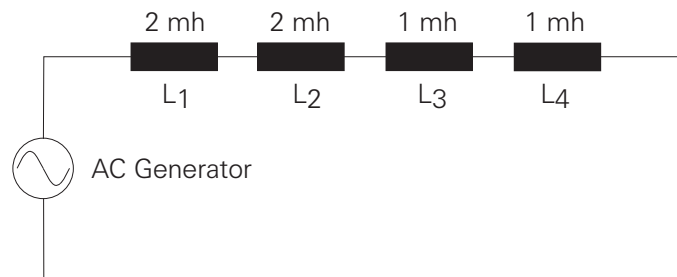

$$L_t = L_1 + L_2 + L_3 + L_4$$

$$L_t = 2 \text{ mh} + 2 \text{ mh} + 1 \text{ mh} + 1 \text{ mh}$$

$$L_t = 6 \text{ mh}$$

Formula for Parallel Inductors

In the following circuit, an AC generator is used to supply electrical power to three inductors. Total inductance is calculated using the following formula:

$$\frac{1}{L_t} = \frac{1}{L_1} + \frac{1}{L_2} + \frac{1}{L_3} \dots + \frac{1}{L_n}$$

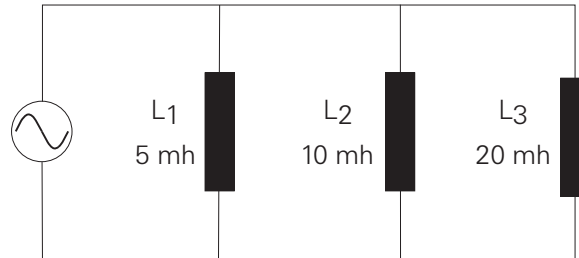

$$\frac{1}{L_t} = \frac{1}{5} + \frac{1}{10} + \frac{1}{20}$$

$$\frac{1}{L_t} = \frac{7}{20}$$

$$L_t = \frac{20}{7}$$

$$L_t = 2.86 \text{ mh}$$

Capacitance

Capacitance and Capacitors

Capacitance is a measure of a circuit's ability to store an electrical charge. A device manufactured to have a specific amount of capacitance is called a **capacitor**. A capacitor is made up of a pair of conductive plates separated by a thin layer of insulating material. Another name for the insulating material is dielectric material. When a voltage is applied to the plates, electrons are forced onto one plate. That plate has an excess of electrons while the other plate has a deficiency of electrons. The plate with an excess of electrons is negatively charged. The plate with a deficiency of electrons is positively charged.

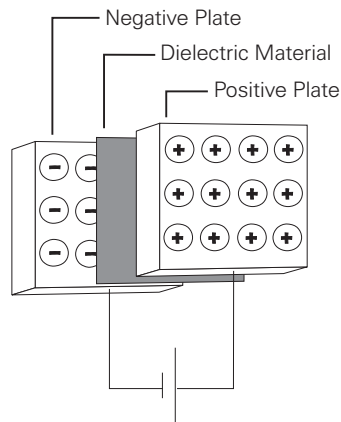

Direct current cannot flow through the dielectric material because it is an insulator; however, the electric field created when the capacitor is charged is felt through the dielectric. Capacitors are rated for the amount of charge they can hold. The capacitance of a capacitor depends on the area of the plates, the distance between the plates, and type of dielectric material used. The unit of measurement for capacitance is **farads** (F). However, the farad is a large unit and capacitors are often rated in microfarads (μF) or picofarads (pF).

Capacitor Circuit Symbols

Capacitance is usually indicated symbolically on an electrical drawing by a combination of a straight line with a curved line, or two straight lines.

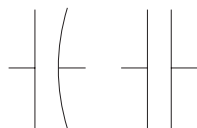

Simple Capacitive Circuit

For the purpose of explanation, a DC circuit is used here to describe the operation of an capacitor. The resistance of wiring and stray values of capacitance found in any circuit are not considered in this explanation.

In a resistive circuit, voltage change is instantaneous. In a circuit with a resistor and capacitor in series, the voltage across the capacitor does not change as quickly. In the following circuit, initially the switch is in position 2 and no voltage is measured by the voltmeter (V). When the switch is moved to position 1, voltage across the capacitor will rise rapidly at first, then more slowly as the maximum value is approached.

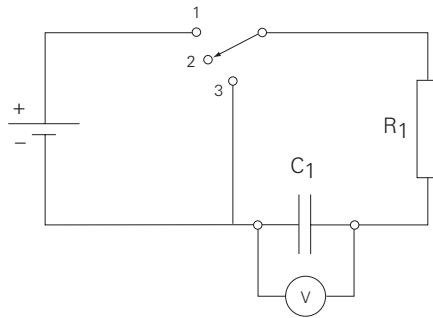

Capacitive Time Constant

The time required for voltage across the capacitor in this simple circuit to rise to its maximum value is determined by the product of capacitance, in farads, times resistance, in ohms. This product is the time constant of a capacitive circuit. The time constant gives the time in seconds required for voltage across the capacitor to reach 63.2% of its maximum value. When the switch in the previous circuit is moved to position 1, the voltage measured by the voltmeter will begin to rise. During the first time constant, voltage will rise to 63.2% of its maximum value. During the second time constant, voltage will rise to 86.4%. It takes about five time constants for voltage across the capacitor to reach its maximum value.

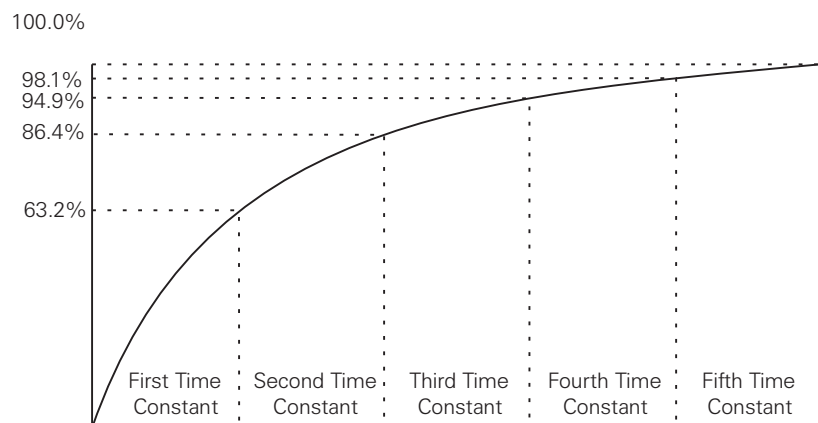

The voltage across the capacitor will reach its maximum value when it is equal to the supply voltage. At that point, current flow will reach zero.

When the switch in the previous circuit is returned to position 2, the capacitor will retain its charge because there is no path for current flow. When the switch is moved to position 3, the capacitor will begin to discharge, and it will take about five time constants for the voltage across the capacitor and the current through the resistor to reach zero.

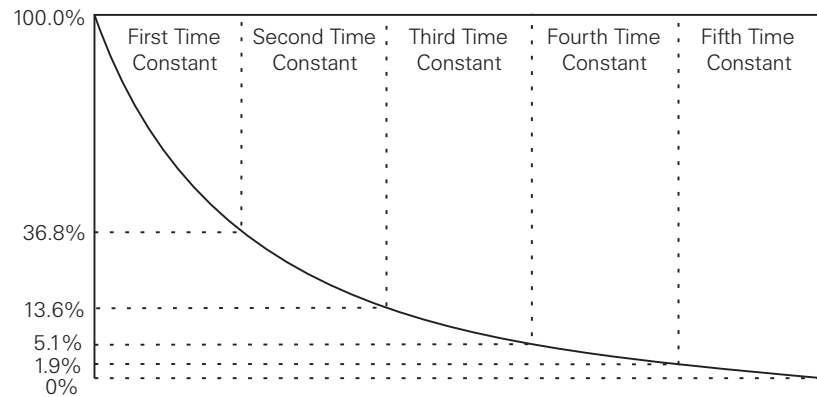

Calculating the Time Constant of a Capacitive Circuit

To determine the time constant of a capacitive circuit, use one of the following formulas:

$$\begin{aligned} \tau \text{ (in seconds)} &= R \text{ (megohms)} \times C \text{ (microfarads)} \\ \tau \text{ (in microseconds)} &= R \text{ (megohms)} \times C \text{ (picofarads)} \\ \tau \text{ (in microseconds)} &= R \text{ (ohms)} \times C \text{ (microfarads)} \end{aligned}$$

In the following illustration, C_1 is equal to $2 \mu\text{F}$, and R_1 is equal to 10Ω . When the switch is closed, it will take 20 microseconds for voltage across the capacitor to rise from zero to 63.2% of its maximum value. It will take about five time constants, 100 microseconds, for this voltage to rise to its maximum value.

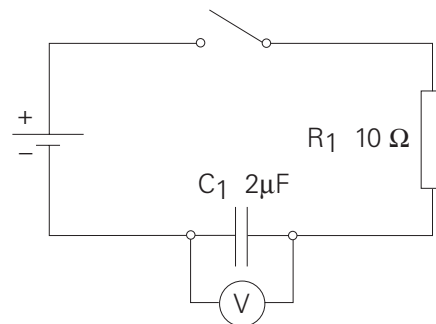

$$\begin{aligned} \tau &= RC \\ \tau &= 2\mu\text{F} \times 10 \Omega \\ \tau &= 20 \text{ microseconds} \end{aligned}$$

Formula for Series Capacitors

Connecting capacitors in series decreases total capacitance. The formula for series capacitors is similar to the formula for parallel resistors. In the following circuit, an AC generator supplies electrical power to three capacitors. Total capacitance is calculated using the following formula:

$$\frac{1}{C_t} = \frac{1}{C_1} + \frac{1}{C_2} + \frac{1}{C_3} \dots + \frac{1}{C_n}$$

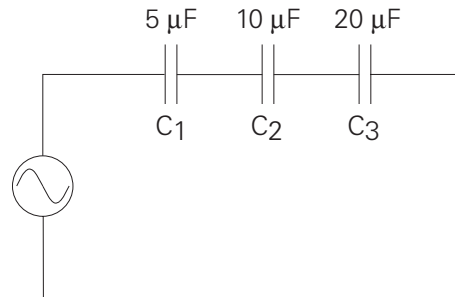

$$\frac{1}{C_t} = \frac{1}{5} + \frac{1}{10} + \frac{1}{20}$$

$$\frac{1}{C_t} = \frac{7}{20}$$

$$C_t = \frac{20}{7}$$

Formula for Parallel Capacitors

Adding capacitors in parallel increases circuit capacitance. In the following circuit, an AC generator is used to supply electrical power to three capacitors. Total capacitance is calculated using the following formula:

$$C_t = C_1 + C_2 + C_3 \dots + C_n$$

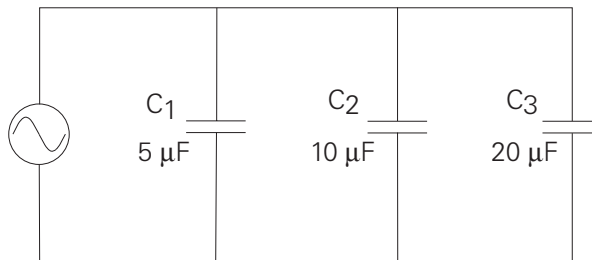

$$C_t = 5 \mu\text{F} + 10 \mu\text{F} + 20 \mu\text{F}$$

$$C_t = 35 \mu\text{F}$$

Review 8

1. The total inductance for this circuit is _____ mh.

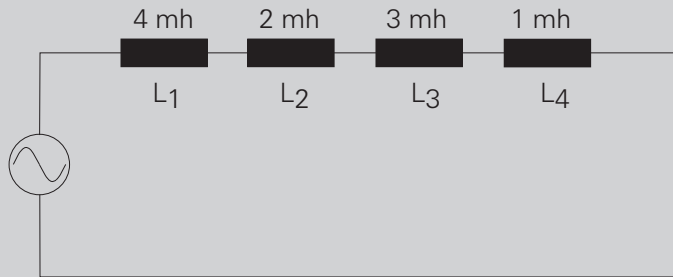

2. The total inductance for this circuit is _____ mh.

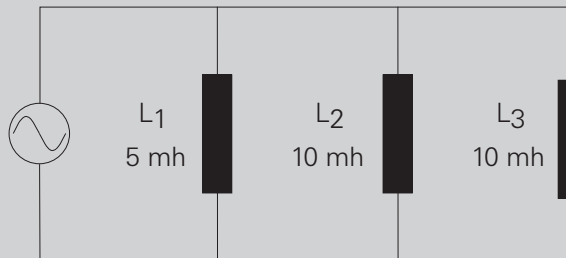

3. The total capacitance for this circuit is _____ μF .

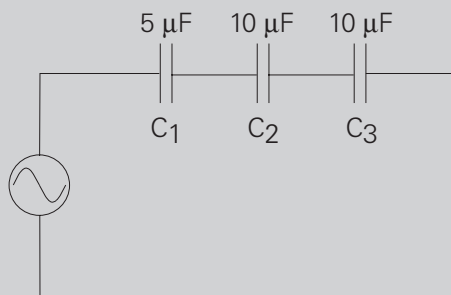

4. The total capacitance for this circuit is _____ μF .

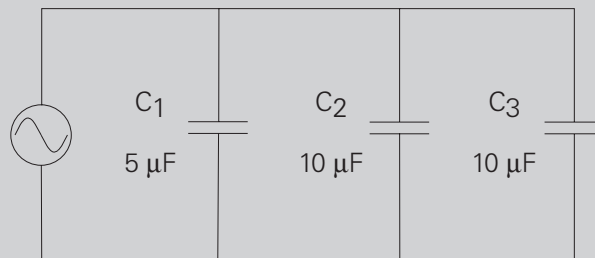

Inductive and Capacitive Reactance

In a purely resistive AC circuit, resistance is the only opposition to current flow. In an AC circuit with only inductance, capacitance, or both inductance and capacitance, but no resistance, opposition to current flow is called **reactance**, designated by the symbol "X." Total opposition to current flow in an AC circuit that contains both reactance and resistance is called **impedance**, designated by the symbol "Z." Just like resistance, reactance and impedance are expressed in ohms.

Inductive Reactance

Inductance only affects current flow when the current is changing. Inductance produces a self-induced voltage (counter emf) that opposes changes in current. In an AC circuit, current is changing constantly. Inductance in an AC circuit, therefore, causes a continual opposition. This opposition to current flow is called **inductive reactance** and is designated by the symbol " X_L ."

Inductive reactance is proportional to both the inductance and the frequency applied. The formula for inductive reactance is:

$$X_L = 2\pi fL$$
$$X_L = 2 \times 3.14 \times \text{frequency} \times \text{inductance}$$

For a 60 hertz circuit containing a 10 mh inductor, the inductive reactance is:

$$X_L = 2\pi fL$$
$$X_L = 2 \times 3.14 \times 60 \times 0.010$$
$$X_L = 3.768 \Omega$$

For this example, the resistance is zero so the impedance is equal to the reactance. If the voltage is known, Ohm's Law can be used to calculate the current. If, for example, the voltage is 10 volts, the current is calculated as follows;

$$I = \frac{E}{Z}$$
$$I = \frac{10}{3.768}$$
$$I = 2.65 \text{ Amps}$$

Phase Relationship between Current and Voltage in an Inductive Circuit

In a purely resistive circuit, current and voltage rise and fall at the same time. They are said to be "in phase." In this circuit, there is no inductance. Resistance and impedance are the same.

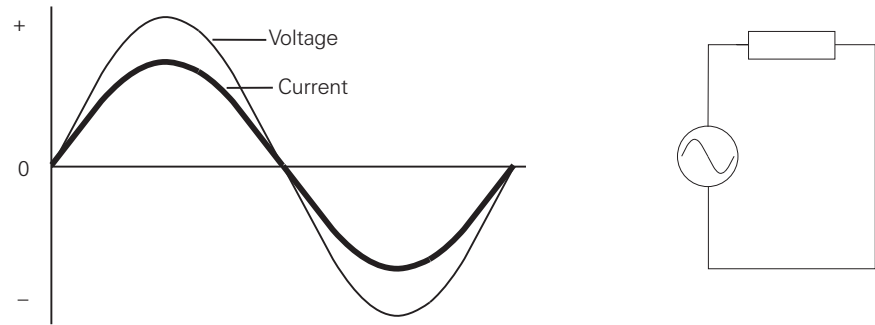

In a purely inductive circuit, current lags behind voltage by 90 degrees. Current and voltage are said to be "out of phase." In this circuit, impedance and inductive reactance are the same.

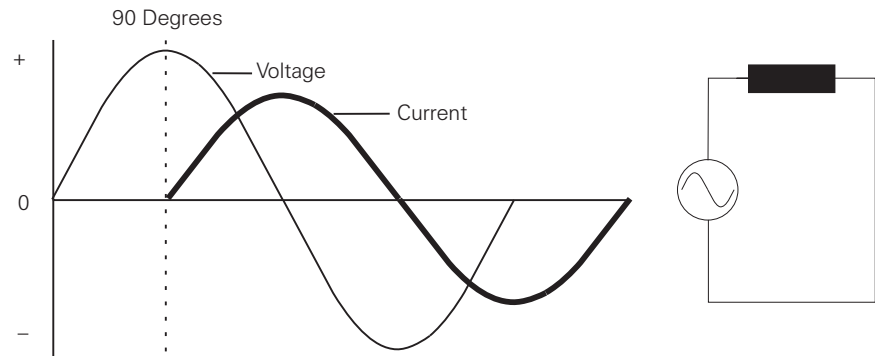

In a circuit with both resistance and inductive reactance, AC current will lag the voltage by more than 0 degrees and less than 90 degrees. The exact amount of lag will depend upon the relative amounts of resistance and inductive reactance. The more resistive a circuit is, the closer it is to being in phase. The more reactive a circuit is, the more out of phase it is. In the following illustration, resistance and inductive reactance are equal. Current lags voltage by 45 degrees.

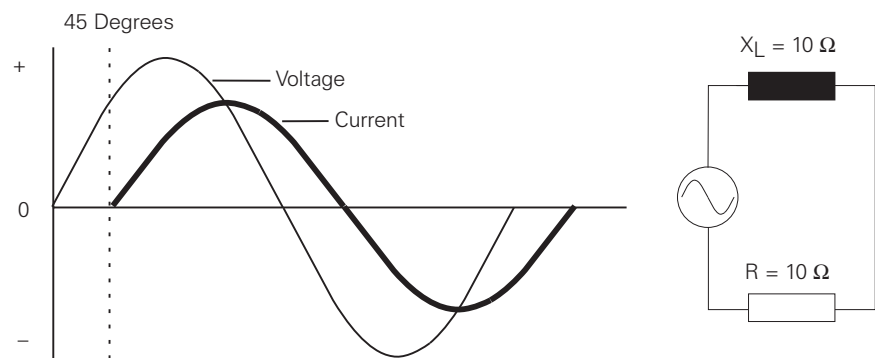

Calculating Impedance in an Inductive Circuit

When working with a circuit containing elements of inductance, capacitance, and resistance, impedance must be calculated. Because electrical concepts deal with trigonometric functions, this is not a simple matter of subtraction and addition. The following formula is used to calculate impedance in a circuit with resistance and inductive reactance:

$$Z = \sqrt{R^2 + X_L^2}$$

In the previous example, resistance and inductive reactance are each 10 ohms. Impedance for this circuit can be calculated as follows:

$$Z = \sqrt{10^2 + 10^2}$$

$$Z = \sqrt{200}$$

$$Z = 14.1421 \Omega$$

Vectors

A common way to represent AC circuit values is with a vector. A vector is a graphic representation of a quantity that has direction and magnitude. A vector on a map might indicate that one city is 50 miles southwest from another. The magnitude is 50 miles and the direction is southwest. Vectors are also used to show electrical relationships.

The following vector illustrates the relationship between resistance and inductive reactance for a circuit containing 10 ohms of each. The angle between the vectors is the phase angle represented by the symbol θ . When inductive reactance is equal to resistance the resultant angle is 45 degrees. This angle represents how much current lags voltage for this circuit.

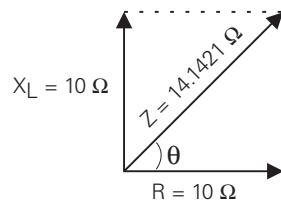

Capacitive Reactance

Capacitance also opposes AC current flow. **Capacitive reactance** is designated by the symbol X_C . The larger the capacitor, the smaller the capacitive reactance. Current flow in a capacitive AC circuit is also dependent on frequency. The following formula is used to calculate capacitive reactance:

$$X_C = \frac{1}{2\pi fC}$$

The capacitive reactance for a 60 hertz circuit with a 10 microfarad capacitor is calculated as follows:

$$X_C = \frac{1}{2\pi fC}$$

$$X_C = \frac{1}{2 \times 3.14 \times 60 \times 0.000010}$$

$$X_C = 265.39 \Omega$$

For this example, the resistance is zero so the impedance is equal to the reactance. If the voltage is known, Ohm's Law can be used to calculate the current. If, for example, the voltage is 10 volts, the current is calculated as follows:

$$I = \frac{E}{Z}$$

$$I = \frac{10}{265.39}$$

$$I = 0.0376 \text{ Amps}$$

Phase Relationship between Current and Voltage

The phase relationship between current and voltage are opposite to the phase relationship of an inductive circuit. In a purely capacitive circuit, current leads voltage by 90 degrees.

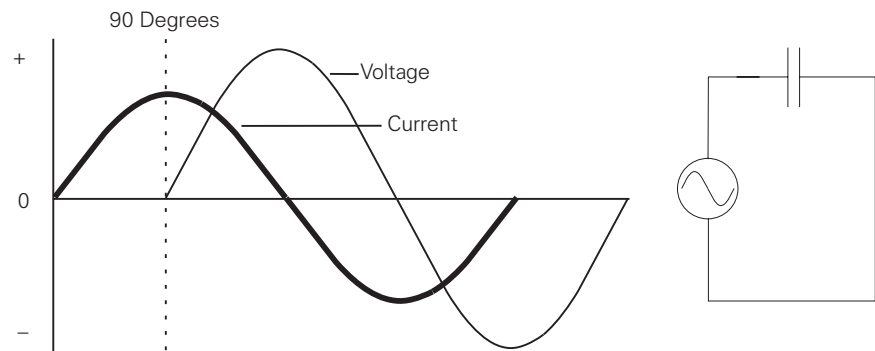

In a circuit with both resistance and capacitive reactance, AC current will lead the voltage by more than 0 degrees and less than 90 degrees. The exact amount of lead will depend upon the relative amounts of resistance and capacitive reactance. The more resistive a circuit is, the closer it is to being in phase. The more reactive a circuit is, the more out of phase it is. In the following illustration, resistance and capacitive reactance are equal. Current leads voltage by 45 degrees.

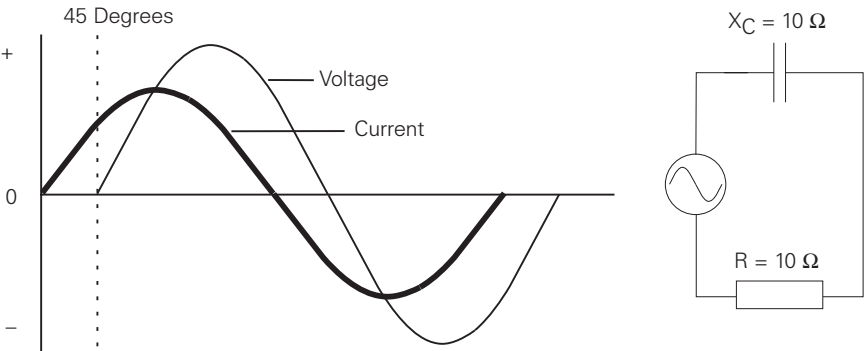

Calculating Impedance in a Capacitive Circuit

The following formula is used to calculate impedance in a circuit with resistance and capacitive reactance:

$$Z = \sqrt{R^2 + X_C^2}$$

In the previous example, resistance and capacitive reactance are each 10 ohms. Impedance for this circuit can be calculated as follows:

$$Z = \sqrt{10^2 + 10^2}$$

$$Z = \sqrt{200}$$

$$Z = 14.1421 \Omega$$

The following vector illustrates the relationship between resistance and capacitive reactance for a circuit containing 10 ohms of each. The angle between the vectors is the phase angle represented by the symbol θ . When capacitive reactance is equal to resistance, the resultant angle is 45 degrees. This angle represents how much current leads voltage for this circuit.

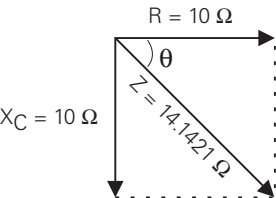

Review 9

1. Opposition to current flow in an AC circuit caused by inductors and capacitors is called _____ .
2. Total opposition to current flow in an AC circuit with both resistance and reactance is called _____ .
3. In a 50 hertz circuit, containing a 10 mh inductor, the inductive reactance is _____ ohms.
4. In a purely inductive circuit, _____
 - a. current and voltage are in phase
 - b. current leads voltage by 90 degrees
 - c. current lags voltage by 90 degrees
5. In a purely capacitive circuit, _____
 - a. current and voltage are in phase
 - b. current leads voltage by 90 degrees
 - c. current lags voltage by 90 degrees
6. In a 50 hertz circuit, containing a 10 microfarad capacitor, the capacitive reactance is _____ ohms.
7. In a circuit with 5 Ω resistance, and 10 Ω inductive reactance, impedance is _____ ohms.
8. In a circuit with 5 Ω resistance, and 4 Ω capacitive reactance, impedance is _____ ohms.

Series R-L-C Circuit

Circuits often contain elements of resistance, inductance, and capacitance. In an inductive AC circuit, current lags voltage by 90 degrees. In a capacitive AC circuit, current leads voltage by 90 degrees. When represented in vector form, inductive and capacitive reactance are 180 degrees apart. As a result, the net reactance is determined by taking the difference between the two quantities.

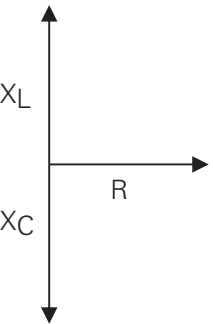

An AC circuit is:

- Resistive if X_L and X_C are equal
- Inductive if X_L is greater than X_C
- Capacitive if X_C is greater than X_L

Calculating Total Impedance in a Series R-L-C Circuit

The following formula is used to calculate total impedance of a circuit containing resistance, capacitance, and inductance:

$$Z = \sqrt{R^2 + (X_L - X_C)^2}$$

In the case where inductive reactance is greater than capacitive reactance, subtracting X_C from X_L results in a positive number. The positive phase angle is an indicator that the net circuit reactance is inductive, and current lags voltage.

In the case where capacitive reactance is greater than inductive reactance, subtracting X_C from X_L results in a negative number. The negative phase angle is an indicator that the net circuit reactance is capacitive and current leads voltage. In either case, the value squared will result in a positive number.

Calculating Reactance and Impedance in a Series R-L-C Circuit

In the following 120 volt, 60 hertz circuit, resistance is 1000 Ω , inductance is 5 mh, and capacitance is 2 μ F. The following example shows the method for calculating impedance for this circuit.

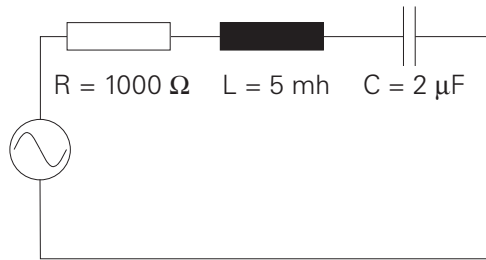

$$X_L = 2\pi fL$$

$$X_L = 6.28 \times 60 \times 0.005$$

$$X_L = 1.884 \Omega$$

$$X_C = \frac{1}{2\pi fC}$$

$$X_C = \frac{1}{6.28 \times 60 \times 0.000002}$$

$$X_C = 1,327 \Omega$$

$$Z = \sqrt{R^2 + (X_L - X_C)^2}$$

$$Z = \sqrt{1000^2 + (1.884 - 1,327)^2}$$

$$Z = \sqrt{1,000,000 + (-1,325.116)^2}$$

$$Z = \sqrt{1,000,000 + 1,755,932.41}$$

$$Z = \sqrt{2,755,932.41}$$

$$Z = 1,660.1 \Omega$$

Given that the applied voltage is 120 volts, current can be calculated as follows:

$$I = \frac{E}{Z}$$

$$I = \frac{120}{1,660.1}$$

$$I = 0.0723 \text{ Amps}$$

Parallel R-L-C Circuit

Calculating Impedance in a Parallel R-L-C Circuit

Total impedance (Z_t) can be calculated in a parallel R-L-C circuit if values of resistance and reactance are known. One method of calculating impedance involves first calculating total current, then using the following formula:

$$Z_t = \frac{E_t}{I_t}$$

Total current is the vector sum of current flowing through the resistance plus, the difference between inductive current and capacitive current. This is expressed in the following formula:

$$I_t = \sqrt{I_R^2 + (I_C - I_L)^2}$$

In the following 120 volt, 60 hertz circuit, capacitive reactance is 25Ω , inductive reactance is 50Ω , and resistance is 1000Ω . A simple application of Ohm's Law will find the branch currents. Remember, voltage is constant throughout a parallel circuit.

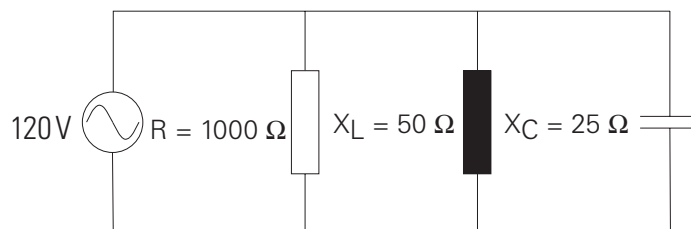

$$I_R = \frac{E}{R}$$

$$I_R = \frac{120}{1000}$$

$$I_R = 0.12 \text{ Amps}$$

$$I_L = \frac{E}{X_L}$$

$$I_L = \frac{120}{50}$$

$$I_L = 2.4 \text{ Amps}$$

$$I_C = \frac{E}{X_C}$$

$$I_C = \frac{120}{25}$$

$$I_C = 4.8 \text{ Amps}$$

Once the branch currents are known, total current can be calculated.

$$I_t = \sqrt{I_R^2 + (I_C - I_L)^2}$$

$$I_t = \sqrt{0.12^2 + (4.8 - 2.4)^2}$$

$$I_t = \sqrt{0.0144 + 5.76}$$

$$I_t = \sqrt{5.7744}$$

$$I_t = 2.403 \text{ Amps}$$

Impedance can then be calculated as follows:

$$Z_t = \frac{E_t}{I_t}$$

$$Z_t = \frac{120}{2.403}$$

$$Z_t = 49.94 \Omega$$

Power and Power Factor in an AC Circuit

Power consumed by a resistor is dissipated in heat and not returned to the source. This is called **true power** because it is the rate at which energy is used.

Current in an AC circuit rises to peak values and diminishes to zero many times a second. The energy stored in the magnetic field of an inductor, or plates of a capacitor, is returned to the source when current changes direction.

Although reactive components do not consume energy, they do increase the amount of energy that must be generated to do the same amount of work. The rate at which this non-working energy must be generated is called **reactive power**. If voltage and current are 90 degrees out of phase, as would be the case in a purely capacitive or purely inductive circuit, the average value of true power is equal to zero. There are high positive and negative peak values of power, but when added together the result is zero.

Power in an AC circuit is the vector sum of true power and reactive power. This is called **apparent power**. True power is equal to apparent power in a purely resistive circuit because voltage and current are in phase. Voltage and current are also in phase in a circuit containing equal values of inductive reactance and capacitive reactance. In most circuits, however, apparent power is composed of both true power and reactive power.

True Power and Apparent Power Formulas

The formula for apparent power is:

$$P = EI$$

Apparent power is measured in volt-amperes (VA).

True power is calculated from another trigonometric function, the cosine of the phase angle ($\cos \theta$). The formula for true power is:

$$P = EI \cos \theta$$

In a purely resistive circuit, current and voltage are in phase. There is a zero degree angle displacement between current and voltage. The cosine of zero is one. Multiplying a value by one does not change the value. Therefore, in a purely resistive circuit, the cosine of the angle is ignored.

In a purely reactive circuit, either inductive or capacitive, current and voltage are 90 degrees out of phase. The cosine of 90 degrees is zero. Multiplying a value times zero results in a zero product. Therefore, no power is consumed in a purely reactive circuit.

Calculating Apparent Power in a simple R-L-C Circuit

In the following 120 volt circuit, current is equal to 84.9 mA. Inductive reactance is 100 Ω and capacitive reactance is 1100 Ω . The phase angle is -45 degrees. By referring to a trigonometric table, the cosine of -45 degrees is found to be 0.7071.

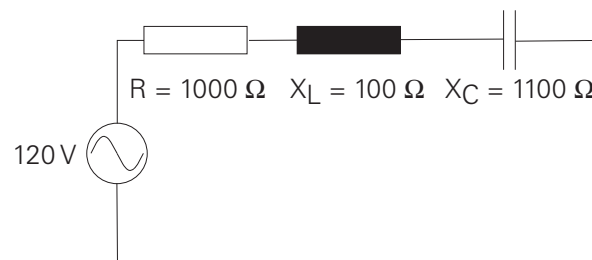

The apparent power consumed by the circuit is:

$$P = EI$$

$$P = 120 \times 0.0849$$

$$P = 10.2 \text{ VA}$$

The true power consumed by the circuit is:

$$P = EI \cos \theta$$

$$P = 120 \times 0.0849 \times 0.7071$$

$$P = 7.2 \text{ Watts}$$

Another formula for true power is:

$$P = I^2R$$

$$P = 0.0849^2 \times 1000$$

$$P = 7.2 \text{ Watts}$$

Power Factor

Power factor is the ratio of true power to apparent power in an AC circuit. Power factor is expressed in the following formula:

$$PF = \frac{\text{True Power}}{\text{Apparent Power}}$$

Power factor can also be expressed using the formulas for true power and apparent power. The value of EI cancels out because it is the same in the numerator and denominator. Power factor is the cosine of the angle.

$$PF = \frac{EI \cos \theta}{EI}$$

$$PF = \cos \theta$$

In a purely resistive circuit, where current and voltage are in phase, there is no angle of displacement between current and voltage. The cosine of a zero degree angle is one. The power factor is one. This means that all energy delivered by the source is consumed by the circuit and dissipated in the form of heat.

In a purely reactive circuit, voltage and current are 90 degrees apart. The cosine of a 90 degree angle is zero. The power factor is zero. This means the circuit returns all energy it receives from the source to the source.

In a circuit where reactance and resistance are equal, voltage and current are displaced by 45 degrees. The cosine of a 45 degree angle is .7071. The power factor is .7071. This means the circuit uses approximately 70% of the energy supplied by the source and returns approximately 30%.

Review 10

1. An AC circuit is _____ if inductive reactance and capacitive reactance are equal.
2. A series AC circuit is _____ if there is more inductive reactance than capacitive reactance.
3. A series AC circuit is _____ if there is more capacitive reactance than inductive reactance.
4. In a 120 VAC, 60 hertz series circuit, with $1000\ \Omega$ of resistance, 10 mh of inductance and $4\ \mu\text{F}$ of capacitance, impedance is _____ Ω and current is _____ amps.
5. For the following circuit, calculate impedance and current.

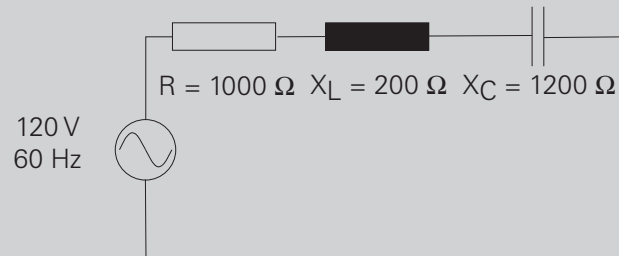

Impedance is _____ Ω , and I_t is _____ amps.

6. For a circuit with a 120 volt AC source and a current of 10 amps, the apparent power is _____ VA.
7. For a circuit with an apparent power of 3000 VA and a power factor of 0.8, the true power is _____ watts.

Transformers

Mutual Induction

Transformers are electromagnetic devices that transfer electrical energy from one circuit to another by **mutual induction**. A single-phase transformer has two coils, a primary and a secondary. Mutual induction is the transfer of electrical energy from the primary to the secondary through magnetic fields. The following circuit illustrates mutual induction. The AC generator provides electrical power to the primary coil. The magnetic field produced by the primary induces a voltage into the secondary coil, which supplies power to a load.

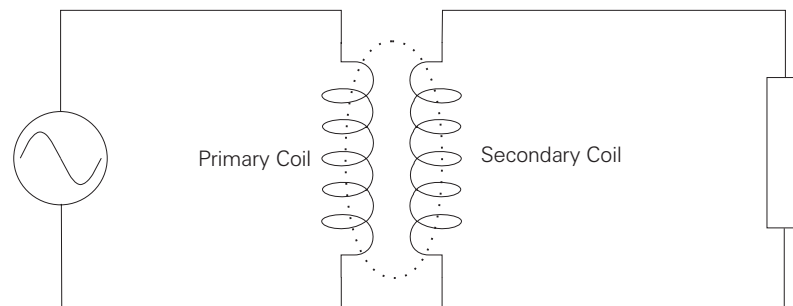

Transformers are used to step a voltage up to a higher level, or down to a lower level. To understand the need to stepping up or down voltages, consider how electrical power is generated and distributed.

Generators used by power companies typically generate voltages of 30 KV or less. While this is a relatively high voltage compared to the voltages used by power customers, it is more efficient for utilities to transmit this power at still higher voltages, up to as high as 765 KV.

The electrical power is received at substation transformers many miles away where it is stepped down and distributed locally. When it arrives at the customer's location, it is further stepped down to the level needed for the type of customer.

Even within a customer's facility, voltage may need to be stepped down further to meet requirements of some equipment.

This process of stepping up or down the voltage throughout a power distribution system is most often accomplished using transformers. The size and ratings of the transformers vary, but the basic operation of these devices is the same.

Coefficient of Coupling

Mutual inductance between two coils depends on their flux linkage. Maximum coupling occurs when all the lines of flux from the primary coil cut through the secondary winding. The amount of coupling which takes place is referred to as **coefficient of coupling**. To maximize coefficient of coupling, both coils are often wound on an iron core which is used to provide a path for the lines of flux. The following discussion of step-up and step-down transformers applies to transformers with an iron core.

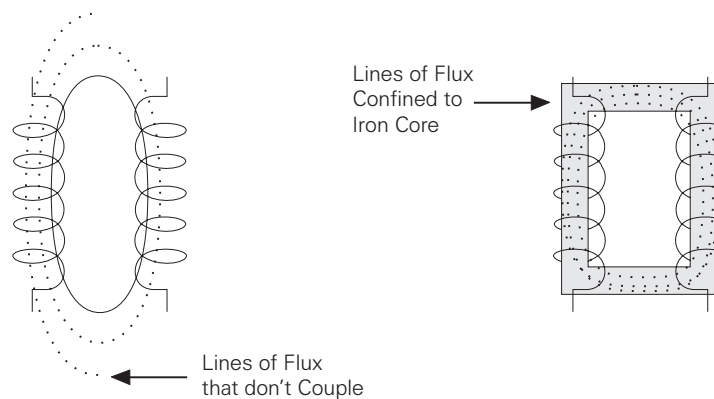

Voltage, Current, and the Number of Turns in a Coil

There is a direct relationship between voltage, impedance, current, and the number of coil turns in a transformer. This relationship can be used to find either primary or secondary voltage, current, and the number of turns in each coil. It is the number of turns which determine if a transformer is a step up or step down transformer. The following "rules-of-thumb" apply to transformers:

- If the primary coil has fewer turns than the secondary coil, the transformer is a **step-up transformer**.
- If the primary coil has more turns than the secondary coil, the transformer is a **step-down transformer**.

When the number of turns on the primary and secondary coils of a transformer are equal, input voltage, impedance, and current are equal to output voltage, impedance, and current.

Step-Up Transformer

A step-up transformer is used when it is desirable to step voltage up in value. The following circuit illustrates a step-up transformer. The primary coil has fewer turns than the secondary coil. When the primary has fewer turns than the secondary, voltage and impedance are stepped up. In the circuit illustrated, The transformer secondary has twice as many turns as the primary and voltage is stepped up from 120 VAC to 240 VAC. Because impedance is also stepped up, current is stepped down from 10 amps to 5 amps.

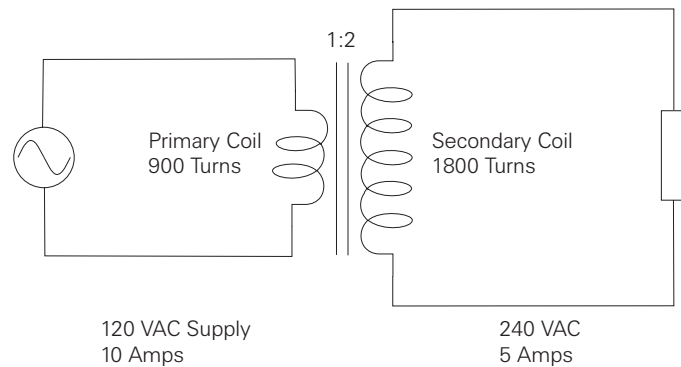

Step-Down Transformer

A step-down transformer is used when it is desirable to step voltage down in value. The following circuit illustrates a step-down transformer. The primary coil has more turns than the secondary coil. The step-down ratio is 2:1. voltage and impedance are stepped down, current is stepped up.

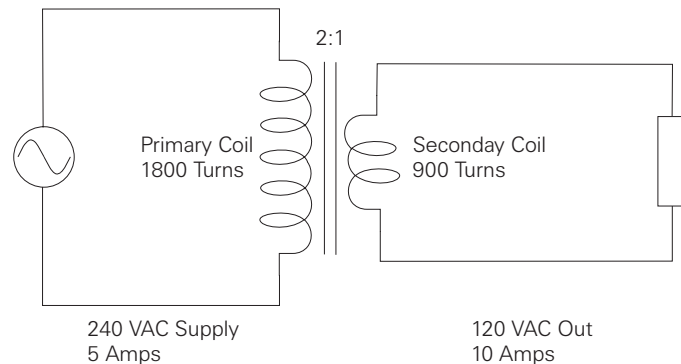

Single-Phase Transformer

120 or 240 VAC **single-phase transformers** are used to supply lighting, receptacle, and small appliance loads. A transformer with a 240 VAC secondary can be used to supply 240 VAC to larger appliances such as stoves, air conditioners and heaters. A 240 VAC secondary can be tapped in the center to provide two sources of 120 VAC power.

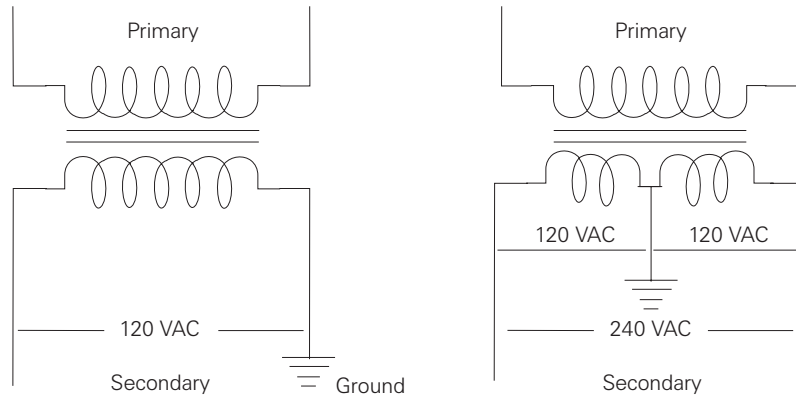

Formulas for Calculating the Number of Primary and Secondary Turns of a Transformer

There are a number of useful formulas for calculating, voltage, current, and the number of turns between the primary and secondary of a transformer. These formulas can be used with either step-up or step-down transformers. The following legend applies to the transformer formulas:

E_S	=	secondary voltage
E_P	=	primary voltage
I_S	=	secondary current
I_P	=	primary current
N_S	=	turns in the secondary coil
N_P	=	turns in the primary coil

To find voltage:

$$E_S = \frac{E_P \times I_P}{I_S} \quad E_P = \frac{E_S \times I_S}{I_P}$$

To find current:

$$I_S = \frac{E_P \times I_P}{E_S} \quad I_P = \frac{E_S \times I_S}{E_P}$$

To find the number of coil turns:

$$N_S = \frac{E_S \times N_P}{E_P} \quad N_P = \frac{E_P \times N_S}{E_S}$$

Using the values for the step-down transformer in the example of the previous page, the secondary voltage can be verified.

$$E_S = \frac{E_P \times I_P}{I_S}$$

$$E_S = \frac{240 \text{ Volts} \times 5 \text{ Amps}}{10 \text{ Amps}}$$

$$E_S = \frac{1200}{10}$$

$$E_S = 120 \text{ Volts}$$

Transformer Ratings

Transformers are rated for the amount of apparent power they can provide. Because values of apparent power are often large, the transformer rating is frequently given in **kVA** (kilovolt-amps). The kVA rating determines the current and voltage a transformer can deliver to its load without overheating. Given kVA and volts, amps can be calculated.

$$\text{kVA} = \frac{\text{Volts} \times \text{Amps}}{1000}$$

$$\text{Amps} = \frac{\text{kVA} \times 1000}{\text{Volts}}$$

Using the illustrated step-down transformer, the kVA rating can be calculated. The kVA rating of a transformer is the same for both the primary and the secondary.

$$\text{Primary kVA} = \frac{240 \times 5}{1000}$$

$$\text{Primary kVA} = 1.2 \text{ kVA}$$

$$\text{Secondary kVA} = \frac{120 \times 10}{1000}$$

$$\text{Secondary kVA} = 1.2 \text{ kVA}$$

Transformer Losses

Most of the electrical energy provided to the primary of a transformer is transferred to the secondary. Some energy, however, is lost in heat in the wiring or the core. Some losses in the core can be reduced by building the core of a number of flat sections called laminations.

Three-Phase Transformers

Delta Connections

Three-phase transformers are used when three-phase power is required for larger loads such as industrial motors. There are two basic three-phase transformer connections, **delta** and **wye**. A delta is like three single-phase transformers connected together. The secondary of a delta transformer is illustrated below. For simplicity, the primary is not shown in this example. The voltages shown on the illustration are examples. Just as with a single-phase transformer, the secondary voltage depends on both the primary voltage and the turns ratio.

Delta transformers are schematically drawn in a triangle. The voltages across each winding of the delta triangle represents one phase of a three phase system. The voltage is always the same between any two wires. A single phase (such as L1 to L2) can be used to supply single phase loads. All three phases are used to supply three phase loads.

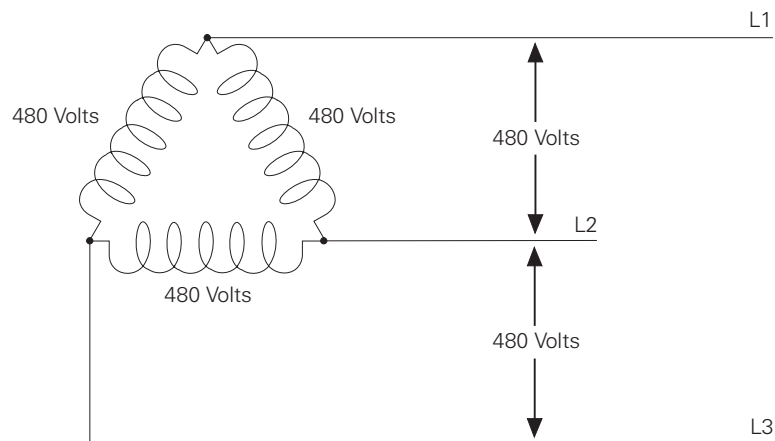

L1 to L2 = 480 volts

L2 to L3 = 480 volts

L1 to L3 = 480 volts

Balanced Delta Current

When current is the same in all three coils, it is said to be **balanced**. In each phase, current has two paths to follow. For example, current flowing from L1 to the connection point at the top of the delta can flow down through one coil to L2, and down through another coil to L3. When current is balanced, the current in each line is equal to the square root of 3 times the current in each coil. The following example shows the line current calculation with the current in each coil equal to 29 amps.

$$I_L = \sqrt{3} \times 29 = 1.732 \times 29 = 50.2 \text{ Amps}$$

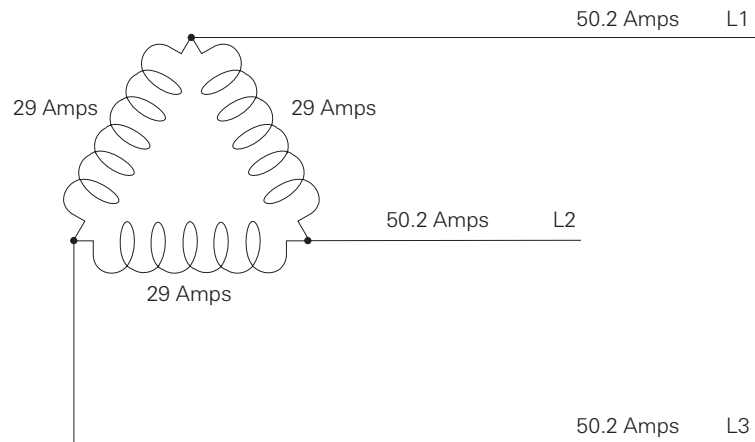

Unbalanced Delta Current

When current is not the same in all three coils, it is **unbalanced**. The following diagram depicts an example of an unbalanced system.

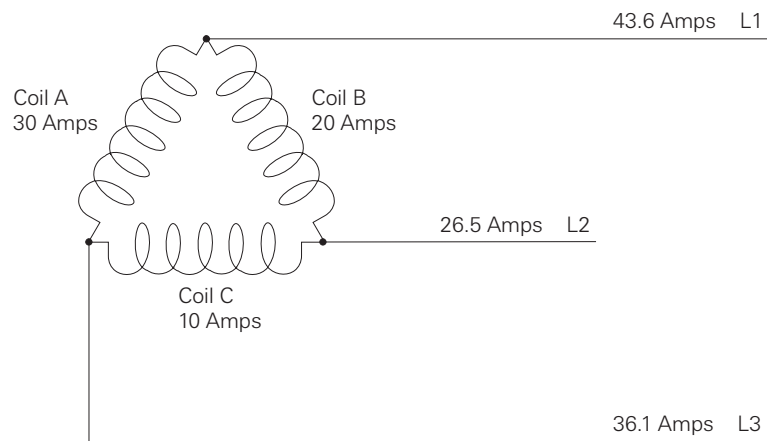

Wye Connections

The wye connection is also known as a star connection. Three coils are connected to form a "Y" shape. The wye transformer secondary has four leads, three phase leads and one neutral lead. The voltage across any phase (line-to-neutral) will always be less than the line-to-line voltage. The line-to-line voltage is the square root of 3 times the line-to-neutral voltage. The following example shows a wye transformer secondary with a line-to-neutral voltage is 277 volts and a line-to-line voltage of 480 volts.

$$E_{\text{Line-to-Line}} = \sqrt{3} \times 277 = 1.732 \times 277 = 480 \text{ Volts}$$

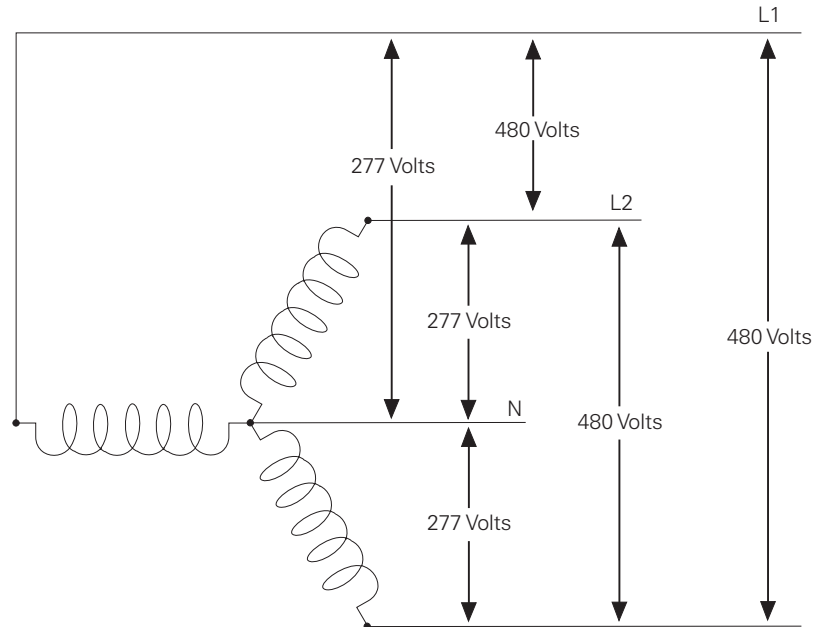

Review 11

1. If the primary of a transformer has more turns than the secondary, it is a _____ transformer.
2. If the primary of a transformer has fewer turns than the secondary, it is a _____ transformer.
3. The secondary voltage of an iron-core transformer with 240 volts on the primary, 40 amps on the primary, and 20 amps on the secondary is _____ volts.
4. A transformer with a 480 volt, 10 amp primary, and a 240 volt, 20 amp secondary will be rated for _____ kVA.
5. A wye connected, three-phase transformer secondary, with 240 volts line-to-line will have _____ volts line-to-neutral.

Review Answers

- Review 1** 1) electron (-), proton (+), neutron (neutral); 2) free electron;
3) many; 4) a, c, e, g; 5) many, few.
- Review 2** 1) electrons; 2) negative; 3) positive; 4) repel, attract; 5) voltage;
6) b; 7) a.
- Review 3** 1) $I = \frac{E}{R}$; 2) amps, volts, ohms; 3) 0.5; 4) 45; 5) 2 amps; 6) 6, 6;
7) 20, 80.
- Review 4** 1) 5; 2) 5.45; 3) 3.33; 4) 12; 5) 6; 6) 2.4, 1.6.
- Review 5** 1) 12, 22; 2) 40, 13.33.
- Review 6** 1) power; 2) E, R, E^2 ; 3) 36; 4) iron, north-south;
5) north, south; 6) left, thumb, lines of flux.
- Review 7** 1) sine wave; 2) 120; 3) one; 4) -129.9 volts;
5) 106.05 volts RMS.
- Review 8** 1) 10; 2) 2.5; 3) 2.5; 4) 25.
- Review 9** 1) reactance; 2) impedance; 3) 3.14; 4) c; 5) b; 6) 318.5;
7) 11.18; 8) 6.4.
- Review 10** 1) resistive; 2) inductive; 3) capacitive; 4) 1198, 0.1;
5) 1414.2, 0.0849; 6) 1200; 7) 2400.
- Review 11** 1) step-down; 2) step-up; 3) 480; 4) 4.8; 5) 138.56.

Final Exam

The final exam is intended to be a learning tool. The book may be used during the exam. A tear-out answer sheet is provided. After completing the test, mail the answer sheet in for grading. A grade of 70% or better is passing. Upon successful completion of the test a certificate will be issued.

Questions

- _____ is a good electrical insulator.
 - copper
 - aluminum
 - silver
 - rubber
- A material with more protons than electrons has a _____.
 - negative charge
 - positive charge
 - neutral charge
 - no charge
- In a simple electric circuit with a 12 volt supply, and a $24\ \Omega$ resistor, current is _____.
 - 2 amps
 - 5 amps
 - 0.2 amps
 - 0.5 amps
- The total resistance in a series circuit containing three, $10\ \Omega$, resistors is _____.
 - $10\ \Omega$
 - $30\ \Omega$
 - $3.33\ \Omega$
 - $100\ \Omega$
- In a 12 volt series circuit where $R_1=10\ \Omega$, $R_2=20\ \Omega$, and $R_3=10\ \Omega$, current flow is _____.
 - 0.3 amps
 - 0.5 amps
 - 0.25 amps
 - 3.33 amps

quickSTEP Online Courses

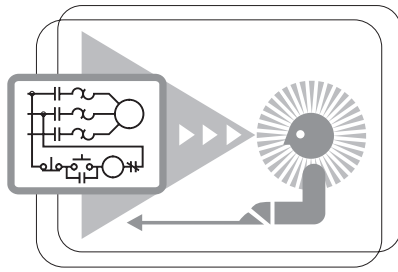

quickSTEP online courses are available at <http://www.sea.siemens.com/step>.

The quickSTEP training site is divided into three sections: Courses, Downloads, and a Glossary. Online courses include reviews, a final exam, the ability to print a certificate of completion, and the opportunity to register in the Sales & Distributor training database to maintain a record of your accomplishments.

From this site the complete text of all STEP courses can be downloaded in PDF format. These files contain the most recent changes and updates to the STEP courses.

A unique feature of the quickSTEP site is our pictorial glossary. The pictorial glossary can be accessed from anywhere within a quickSTEP course. This enables the student to look up an unfamiliar word without leaving the current work area.

